

## User Manual

# T6 Series AC Servo Driver



# T6 AC Servo Driver

T6 Series AC servo products are a cost-effective AC digital servo drive which is designed mainly for position high accurate control, power range up to 1kw, which can provide intelligent performance with efficient configuration methods.

Combined with abundant features such as MFC, vibration suppression, Multi-mode filter function etc., it provides machines a Compact size, low tuning works, high resolution encoder up to 23 bits ,which can be used for high accuracy applications

## Features:

- ◆ Space Vector Modulation (SVM) Technology
- ◆ Efficient configuration methods: 2 parameters related, robust Control
- ◆ Automatic identification for motor type with 17bit/23bit encoder
- ◆ Variety of external command signal: Pulse&Direction
- ◆ Build-in motion engine, internal motion controller used
- ◆ P-N Junction: Exchange power of entire servo drives
- ◆ Encoder output function

## Technical Specification

Model	T6-400RS		T6-750RS		T6-1000RS	
Rated Power (W)	400		750		1000	
Cont current(Arms)	3		5.2		7	
Peak Current(A)	13		18.4		26.5	
Dimension(mm)	175*168*40		175*168*50			
Power Supply	Single phase or three phase 220V -15%~+10% 50/60HZ					
Control Method	IGBT SVPWM sinusoidal wave drive					
Encoder Feedback	<ul style="list-style-type: none"> <li>• 17bit incremental encoder/absolute encoder</li> <li>• 23bit multi-turn absolute encoder</li> </ul>					
IO	Digital IO	Inputs	<ul style="list-style-type: none"> <li>• 4 programmable digital inputs</li> <li>• allows sink input/source input</li> <li>• within the range from 12 VDC to 24 VDC, 30mA</li> </ul>			
		Outputs	<ul style="list-style-type: none"> <li>• 3 programmable digital outputs (2 single-ended, 1 differential)</li> <li>• within the range from 12 VDC to 24 VDC, 30mA</li> </ul>			
	Pulse	Pulse Input	<ul style="list-style-type: none"> <li>• Max. input frequency:</li> <li>• 500 kHz (differential input);</li> <li>• 200kHz (open collector input)</li> </ul>			
	Encoder Output	Pulse Output	Encoder ABZ output (A/B/Z single-ended, Z differential)			
Communication Port	RS232		For configuration connection			
	RS-485		Modbus/RTU, 1:N communication up to 31axes to a host			
Control Mode	<ul style="list-style-type: none"> <li>• Profile Modes/Position/Build-in Position/Build-in Velocity/Jog</li> </ul>					
Operation Interface	Five LED tubes and five keys					
Electronic gear ratio	1~8388608					
Input Function Configuration	Servo-ON. Alarm clear. Positive/Negative Limit. Control mode switching. Gain switching. Deviation counter clear. Command pulse inhibition. Electronic gear switching. Torque limit switching. Speed zero clamp. Speed command sign input. Torque command sign input. E-STOP. Inertia ratio switching. Internal speed selection					

<b>Output Function Configuration</b>		Alarm output. Servo-Ready. Positioning complete. At-speed. Zero-speed. Velocity coincidence. Positional command ON/OFF. Servo-ON. Home-OK
<b>Safety Protection</b>		Over-Current. Over-Voltage. Under-Voltage. Over-Heat. Over-Load. Encoder error. Over-Speed. Running-away. Positive/Negative Limit. Communication error. Position deviation error. Power-line out of
<b>Environment</b>	Temperature	Storage: -20-80°C; Installation: 0-55°C
	Humidity	Under 90%RH (free from condensation)
	Altitude	Lower than 1000m
	Vibration	Less than 0.5G (4.9m/s <sup>2</sup> ) 10-60Hz (non-continuous working)

## Talent Functions

<b>Inertia ratio identification</b>	
Off-line inertia ratio identification, better performance, easy tuning	
<b>Position mode/Velocity mode</b>	
Supported Position mode/Velocity mode/Torque mode	
<ul style="list-style-type: none"> <li>Position mode: Profile position/Pulse &amp; direction/Built-in position/RS232/RS485</li> <li>Velocity mode: Profile velocity/Built-in velocity/RS232/RS485</li> </ul>	
<b>Control mode switching</b>	
IO signal for mode switching, select Position mode/Velocity mode	
<b>Gain switching</b>	
Automatically switch gain under special conditions/ IO signal for gain switching	
<b>16 path build-in position mode/velocity</b>	
No analog control required. Execute by digital IO signal or RS485	
<b>Command pulse inhibition</b>	
Invalid the pulse input, stop with deceleration	
<b>Limit switch</b>	
Protective equipment operation	
<b>Programmable Inputs and Outputs</b>	
<ul style="list-style-type: none"> <li>4 programmable digital inputs</li> <li>3 programmable digital outputs (2 single-ended, 1 differential)</li> </ul>	
<b>Encoder signal output</b>	
Output encoder signal: Single-ended /Differential	
<b>Speed zero clamp</b>	
If the actual analog input is less than the setting value, the motor will stop rotating in servo-on condition	
<b>Vibration Suppression</b>	
Specific resonance frequency can be obtained from PC upper computer software according to waveform monitoring, and filter frequency can be set to effectively suppress the oscillation ripple of a certain frequency in the current instruction.	
<b>Command filter</b>	
To make the positional command divided or multiplied by the electronic gear smooth, set the command filter	
<b>Friction torque compensation</b>	
Apply feed forward torque superposition directly to torque command	

## Connectors and Pin Assignment

Port	Function
CN1	Pulse + Direction Signal Port
CN2	Digital input/output Port
CN3	Encoder Input Port
CN4	RS232( only for tuning ) RS485
CN5	RS485
CN6	Encoder output Port
X1	Power Port

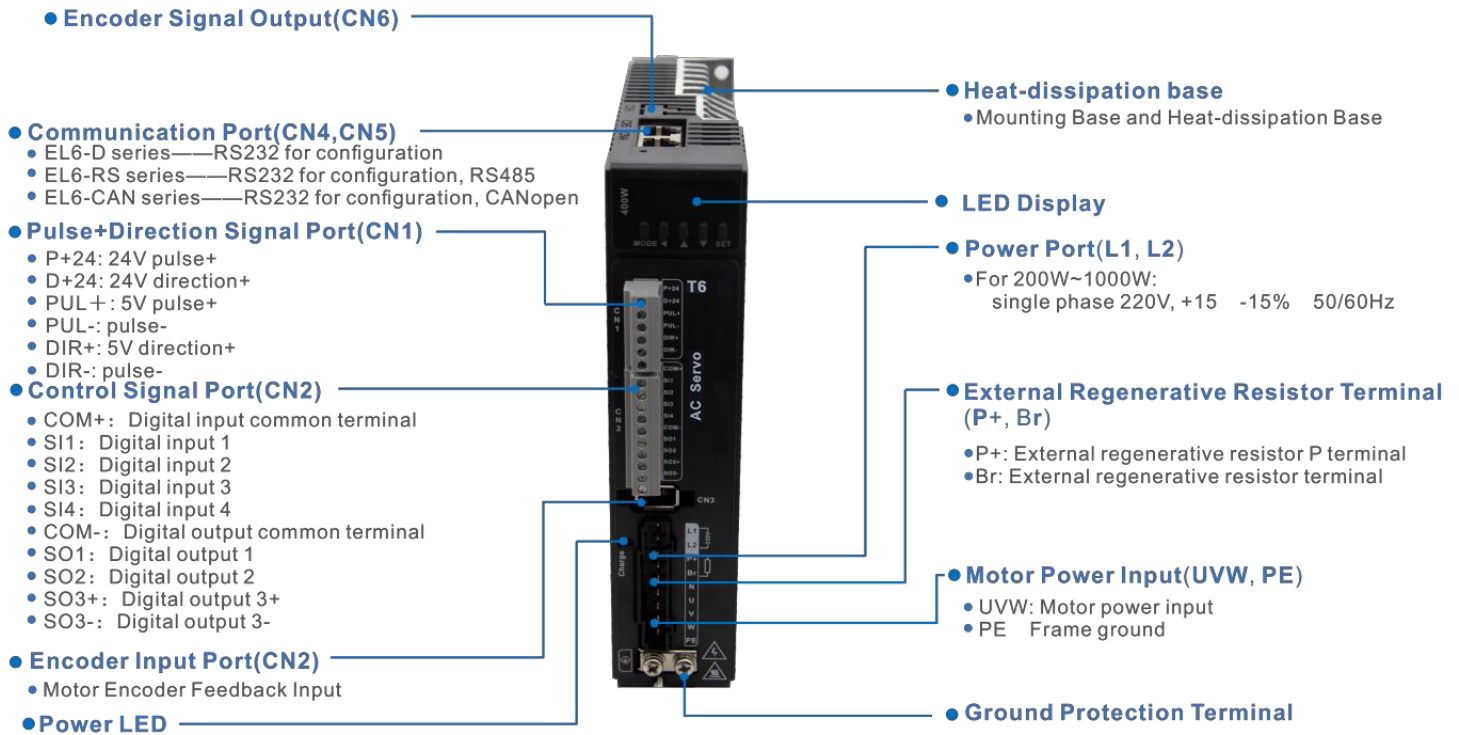

### Signal Explanation of Control Signal Port-CN1 and CN2

Port		Pin	Signal	Name	Explanation
CN1		1	PUL +_24	24V pulse+	Max. input frequency: • 500 kHz (differential input); • 200kHz (open collector input)
		2	DIR +_24	24V	
		3	PUL +	5V pulse+	
		4	PUL -	Pulse-	
		5	DIR +	5V direction+	
		6	DIR -	Direction-	

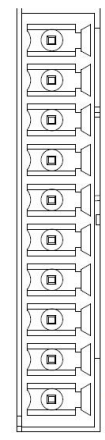
Port		Pin	Signal	Name	Explanation
CN2		1	COM+	Digital input common terminal	4 programmable digital inputs • allows sink input/source input • within the range from 12 VDC to 24 VDC, 30mA
		2	SI1	Digital input 1	
		3	SI2	Digital input 2	
		4	SI3	Digital input 3	
		5	SI4	Digital input 4	• 2 programmable digital single-ended outputs • within the range from 12 VDC to 24 VDC, 30mA
		6	COM -	Digital output common- terminal	
		7	SO1	Digital output 1	
		8	SO2	Digital output 2	• 1 programmable digital differential output • within the range from 12 VDC to 24 VDC, 30mA
		9	SO3 +	Differential Digital output 3	
		10	SO3 -		

**Encoder Input Port-CN3**

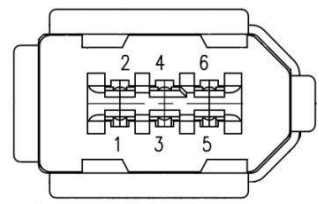
Port		Pin	Signal
CN3		1	VCC5V
		2	GND
		3	BAT+
		4	BAT-
		5	SD+
		6	SD-
			PE

**Bus connector- CN4 and CN5**

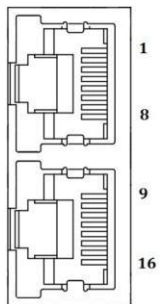
Port		Pin	Signal
CN4 CN5		1, 9	RDO+(RS485
		2, 10	RDO-(RS485-
		3, 11	/
		4, 12	/
		5, 13	/
		6, 14	TXD(RS232)
		7, 15	RXD(RS232)
		8, 16	GND(RS232
			PE

**Encoder output Port-CN6**

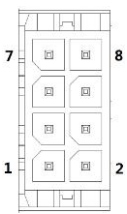
Port		Pin	Signal	Name	Explanation
CN6		1	OCZ	OC output terminal of motor encoder Z phase	Differential output, High >= 2.5vdc, low <= 0.5vdc, maximum current ±20mA
		2	GND	OC output GND terminal of motor encoder	
		3	Z +	Differential output terminal of motor encoder Z phase	
		4	Z -		
		5	B +	Differential output terminal of motor encoder B phase	
		6	B -		
		7	A +	Differential output terminal of motor encoder A phase	
		8	A -		

# Wiring

## Position Control Mode

