

# QUICK START OF T6 AC SERVO



# Table of Contents

Preparation List

Chapter 1 JOG Trail

1.1 Connection

1.2 JOG Trail

Chapter 2 Position Control (Pul + Dir)

2.1 Connection

2.2 Main Steps to Tune T6 Drives in Position Mode

# Preparation List

- T6 drive
- Motor
- Cables
  - Motor power cable
  - Encoder feedback cable
  - Tune cable
  - Drive power cable
- Tune software (Motion Studio)
- The driver of tune software (if it is necessary)

# Chapter 1 JOG Trail

## 1.1 Connection

### 1.1.1 Cables connection.

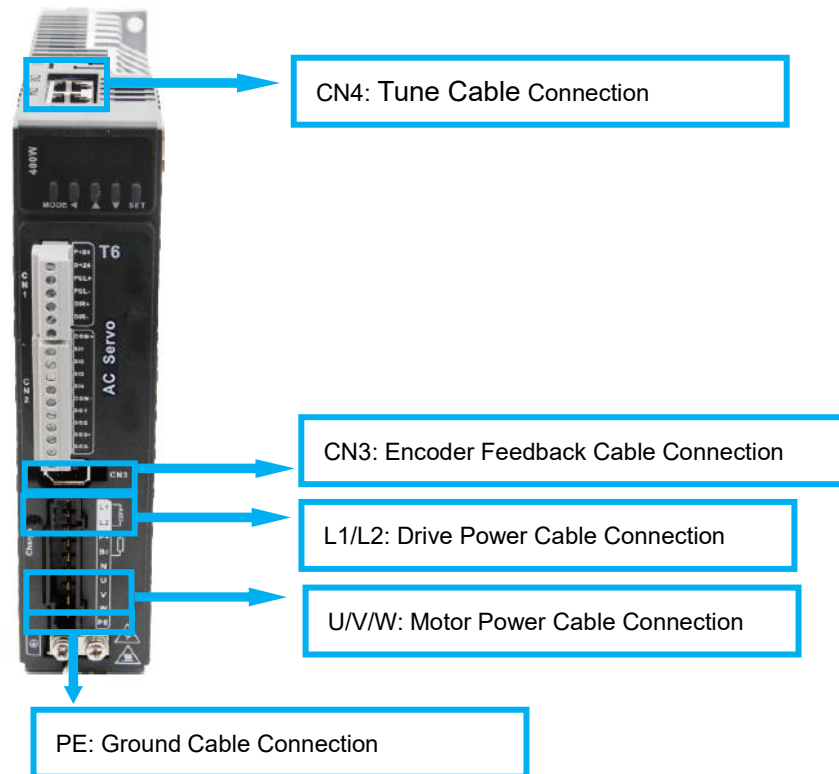

### 1.1.2 Connect to tune software. (Perform this step if it is necessary to install driver)

#### 1.1.2.1 Click in turn “Device Manager”, “Ports (COM&LPT)”, “OYOSTEPER Driver”, “Update driver”.

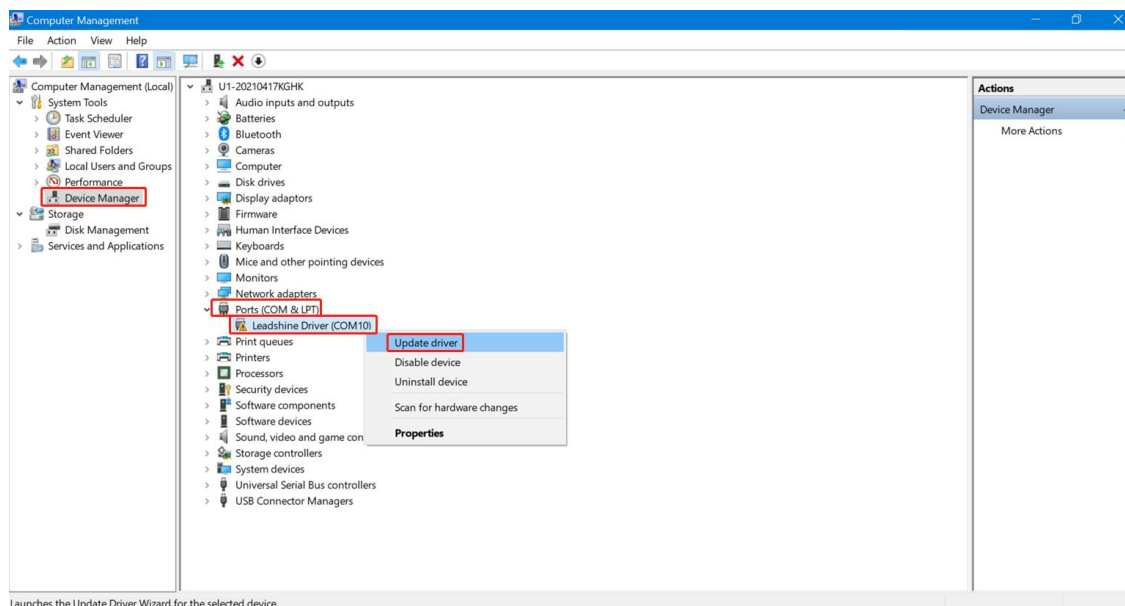

### 1.1.2.2 Click “Browse my computer for drivers”.

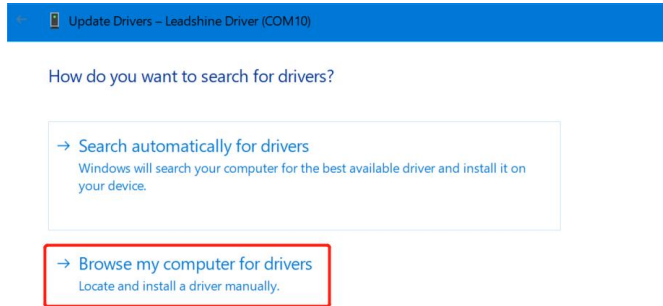

### 1.1.2.3 Search for drivers in the location from “USB\_Driver” folder in which you placed the application that OYOSTEPER provide, and then accomplish updating driver.

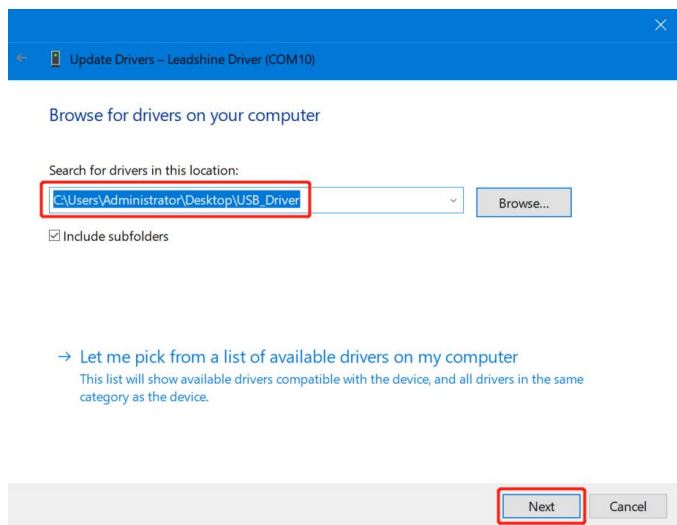

## 1.2 JOG Trail

### 1.2.1 Click icon of Motion Studio to enter in.

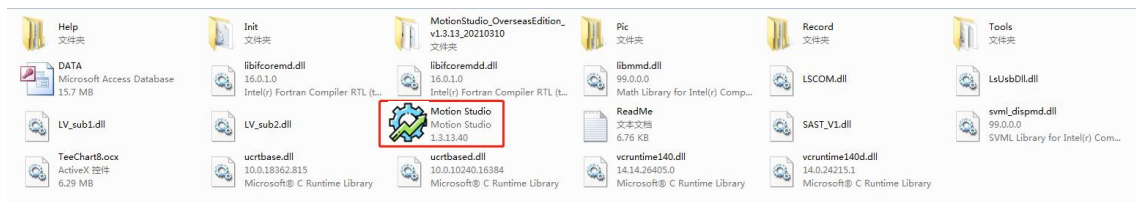

### 1.2.2 Click “Com Connect” , and select appropriate communication port and baud rate to start connecting.

**Note:** Recommend communication port under COM10.

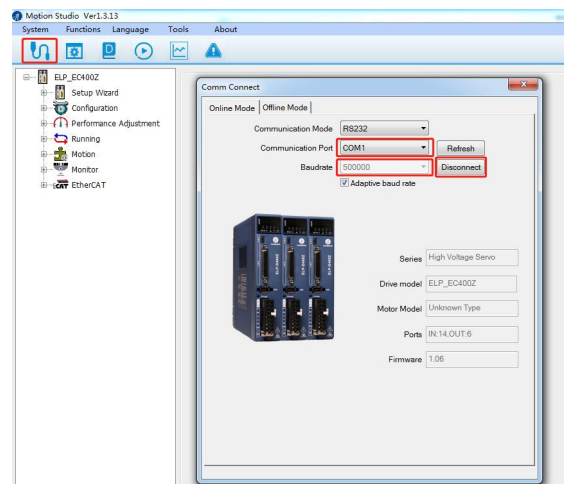

1.2.3 Click “Run Testing ”, and tune Pr0.04 inertia ratio and Pr0.03 stiffness, click “download” to save modified parameters, finally click “Servo Enable” to start JOG trail.

**Note:** All parameters could be modified from

“Parameter Manage ”;

clicking “Download ” is necessary to modified

parameters under “Run Testing ”, not

necessary under “Parameter Manage ”.

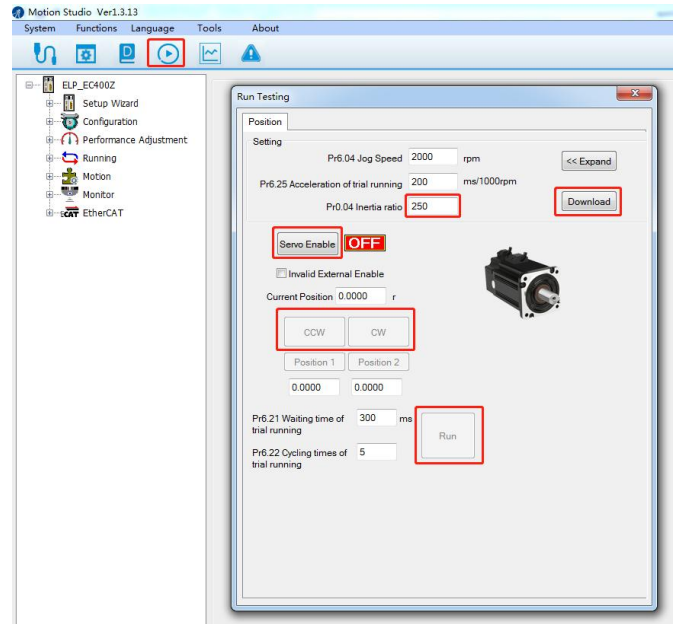

1.2.4 Click “Wave Show ”, and select waveform parameters you want to capture, finally click “Capture” to display real-time waveform.

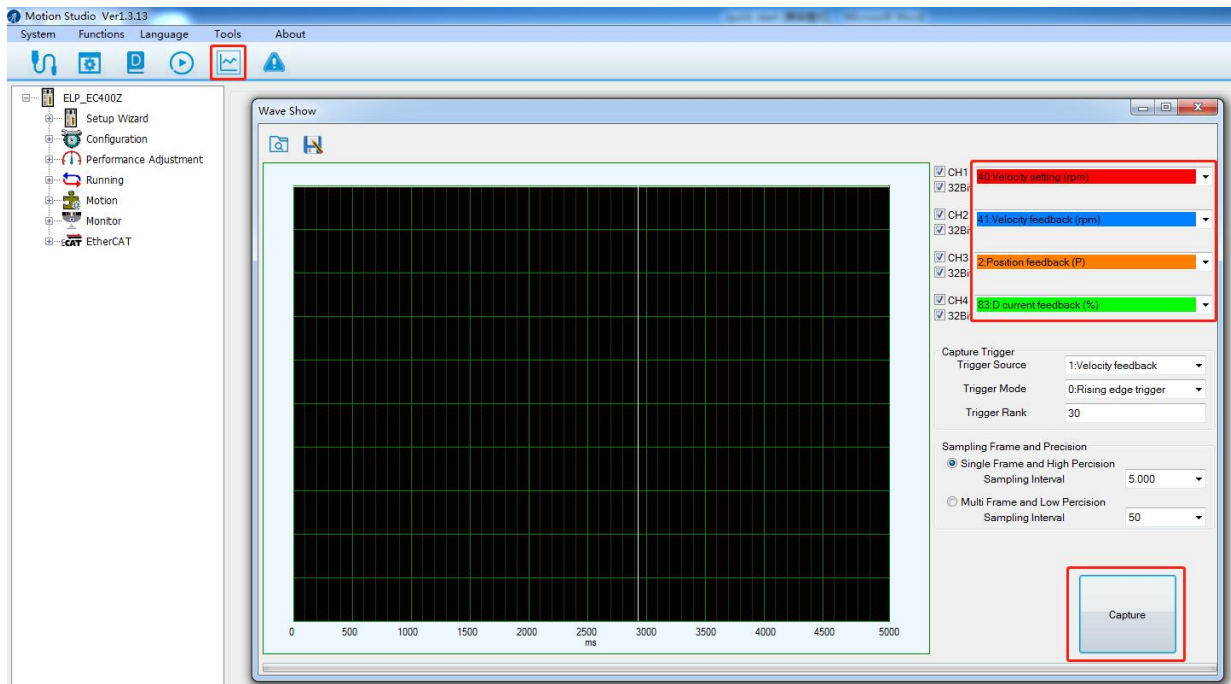

## Chapter 2 Position Control (Pul + Dir)

### 2.1 Connection

#### 2.1.1 Cables connection

##### 2.1.1.1 Cover display.

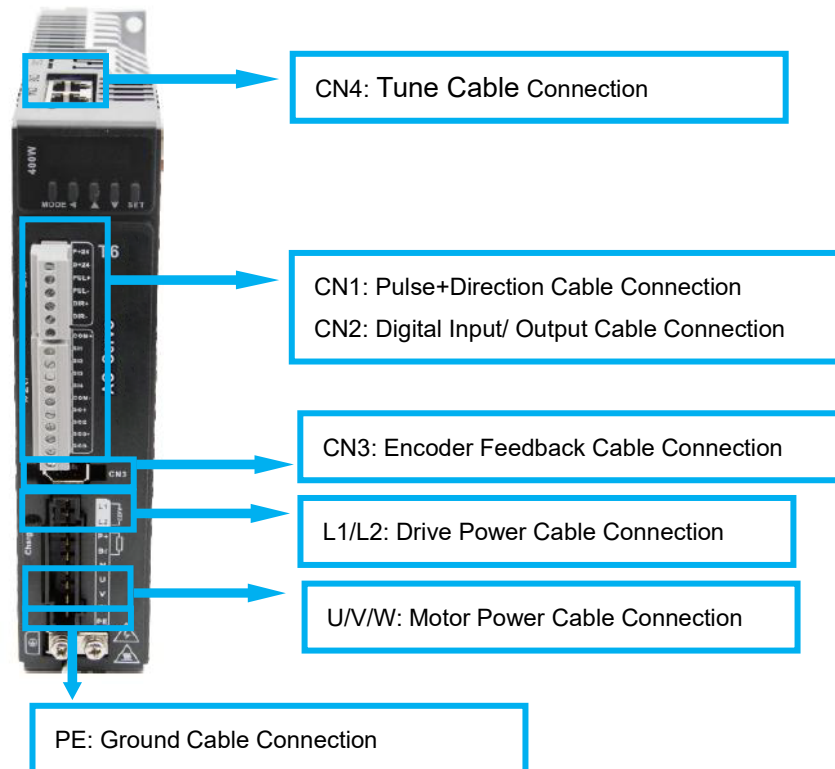

### 2.1.1.2 Wiring sketch map.

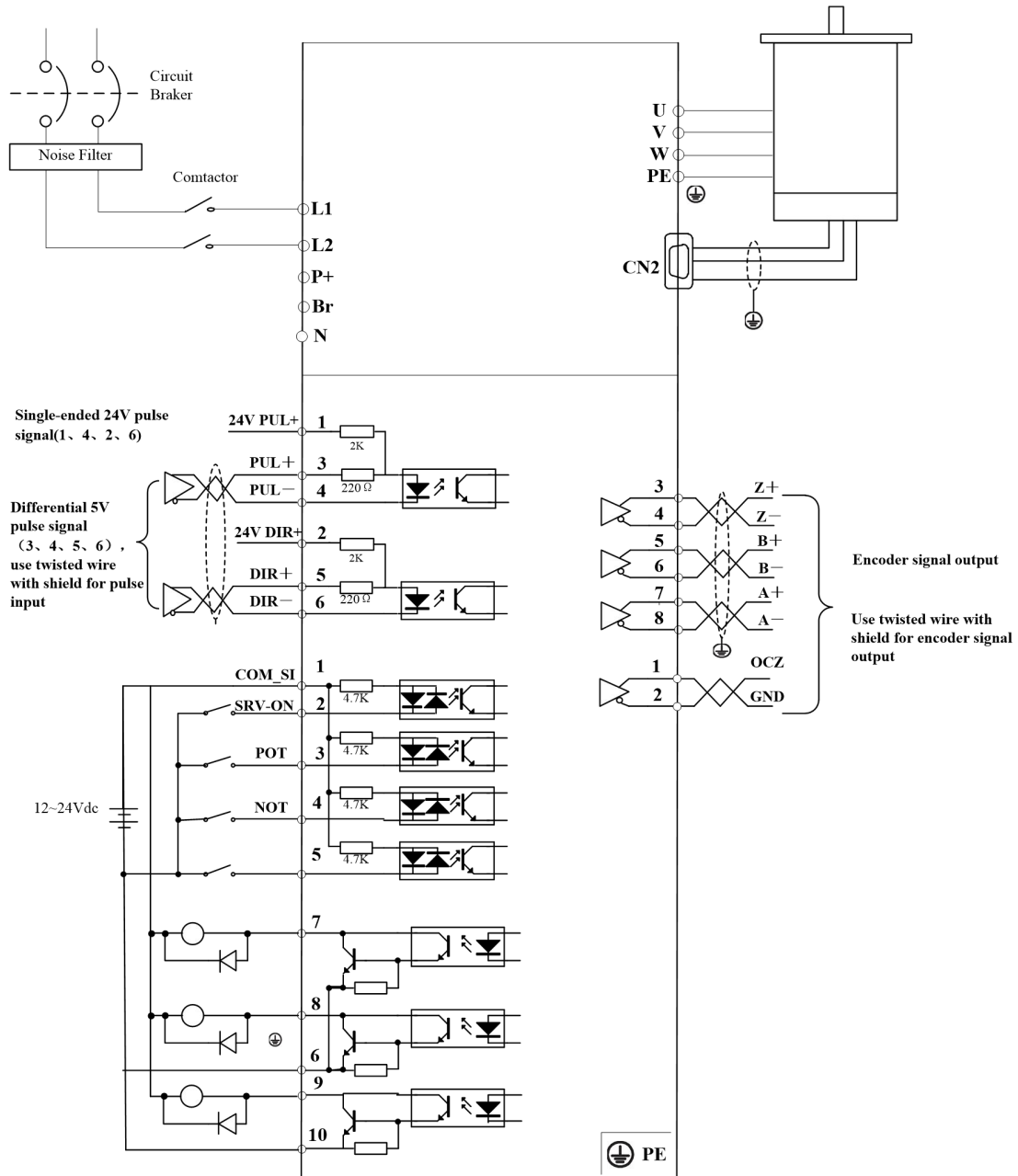

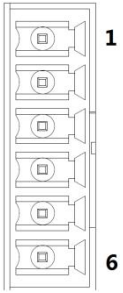

## 2.1.1.3 I/O terminal definition.

Port		Pin	Signal	Name	Explanation
CN1		1	PUL +_24	24V pulse+	Hardware filtering achieves the maximum bandwidth of 750kHz
		2	DIR +_24	24V direction+	
		3	PUL +	5V pulse+	
		4	PUL -	Pulse-	
		5	DIR +	5V direction+	
		6	DIR -	Direction-	

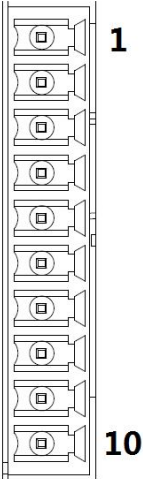
Port		Pin	Signal	Name	Explanation	
CN2		1	COM+	Digital input common terminal, 12VDC~24VDC	Two-way digital input with common terminal, function can be configured. 12VDC ~ 24VDC	
		2	SI1	Digital input 1		
		3	SI2	Digital input 2		
		4	SI3	Digital input 3		
		5	SI4	Digital input 4		
		6	COM -	Digital output common- terminal	Low resistor output in default. OC, the maximum voltage/current is no more than 30V, 50mA.	
		7	SO1	Digital output 1	Recommend the voltage: 12 V-24V. Current :10mA	
		8	SO2	Digital output 2		
		9	SO3 +	Differential Digital output 3	Differential Digital output 3	Differential Digital output , the maximum voltage/current is no more than 30V/50mA . Recommended voltage: 12 -24V. Current :10mA
		10	SO3 -			

### 2.1.1.4 I/O input signal circuit.

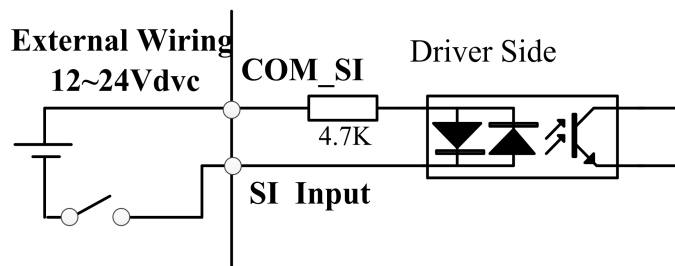

- A.** The power supply is provided by user, DC 12-24V, current  $\geq 100\text{mA}$ , if the power polarity connects reversely, the drive won't run.
- B.** If the drive is enabled by internal signal, then user won't need to connect to Pin1 and Pin2.  
Pr4.00=83 for internal enable.  
Pr4.00=3 for external enable.

### 2.1.1.5 I/O output signal circuit.

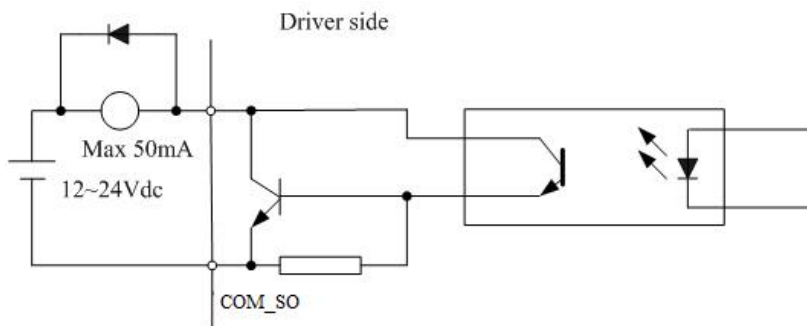

- A.** The power supply is provided by user, if the power polarity connects reversely, the drive will be damaged.
- B.** The output circuit adopts open-collector, the maximum voltage is 25V, and maximum current is 50Ma. If user overlooks the requirements or output terminal directly connected to power supply, the drive will be damaged.
- C.** If the load is inductive load, etc., anti-parallel freewheeling diode must connect to the load, if the freewheeling diode connects reversely, the drive will be damaged.
- D.** Pin 31/32/33/34/35 are for single-ended output, pin 18/19, 20/21 are for differential output.

### 2.1.1.6 Pulse input signal circuit.

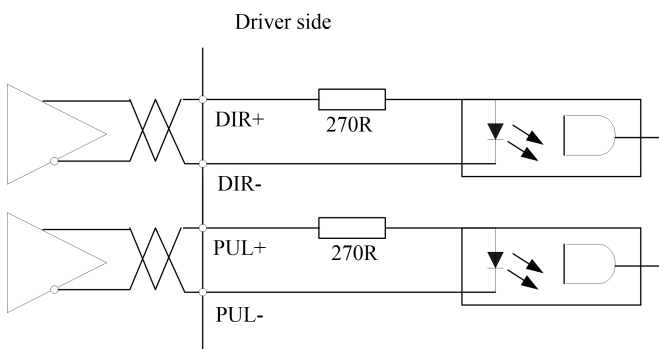

### Wiring method of 5V differential signal (Pin 3/4/5/6)

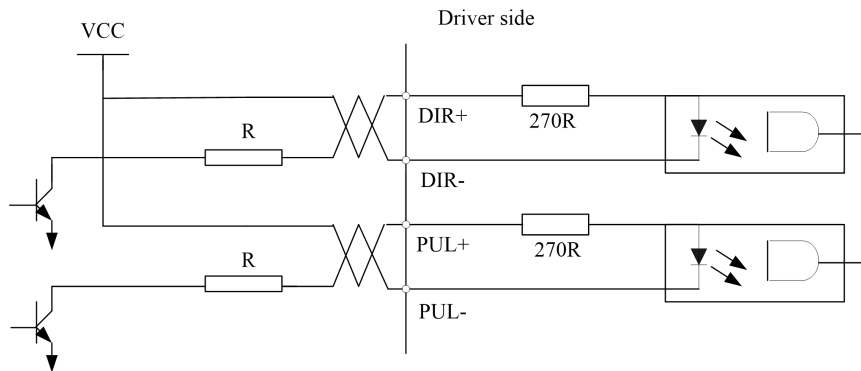

### Wiring method of 24V single-ended signal (Pin 4/6/16/17)

- A. The drive support two wiring methods: 5V differential signal and 24V single-ended signal.
- B. 5V differential signal are recommended to get more accurate pulse signal data.
- C. While 24V single-ended signal are adopted, the power supply is provided by user, if the power polarity connects reversely, the drive will be damaged.
- D. Pulse input signal format show as below chart, in addition, 4 times pulse frequency  $\leq 500\text{kHz}$  while adopting 2 phase input.

### 2.1.2 Connect to tune software. (Perform this step if it is necessary to install driver)

Refer to section 1.1.2 of chapter 1.

## 2.2 Main steps to tune T6 Drives in position mode

- (1) Connect the wire correctly (motor will be recognized by drive automatically );
- (2) Use "run testing" to test the motor if motor run normally or not.
- (3) Set the value of Pr400 (Pr400=83 for external servo on signal ; Pr400=3 for internal signal )
- (4) Choose right control mode Pr0.01. (0: position mode, 1: velocity mode, 2: torque mode).
- (5) Connect the motor with load and Tuning the inertia ratio(Pr0.04)
- (6) Connect the motor with load and Tuning stiffness for each axis (Pr0.02, Pr0.03).
- (7) Tune Pr2.22 and Pr2.23 for smoother moving if needed.
- (8) Set the value of Pr006, 007,008,009,010.
- (9) Tune Pr0.00 for more stiffness if needed.

## Run Testing

Use “run testing” of software protuner to tune the drive. Make sure the shaft of motor is free before running it, and please release the brake firstly if motor is with brake.

### 1. Set parameters for run testing:

Specially pay attention to Pr0.03 Stiffness and Pr0.04 Inertia ratio which strongly corresponding to better performance

### 2. Run testing guidance

Click button “Servo enable”

Click “CCW” to make motor run in CCW direction , click ”Position 1” to save the testing position limit 1

Click “CW” to make motor run in CW direction, click ”Position 2” to save the testing position limit 2

Click ”Run” to start Testing progress

**3. During the Run Testing progress, the wave show monitor the performance of the current parameters setting.**

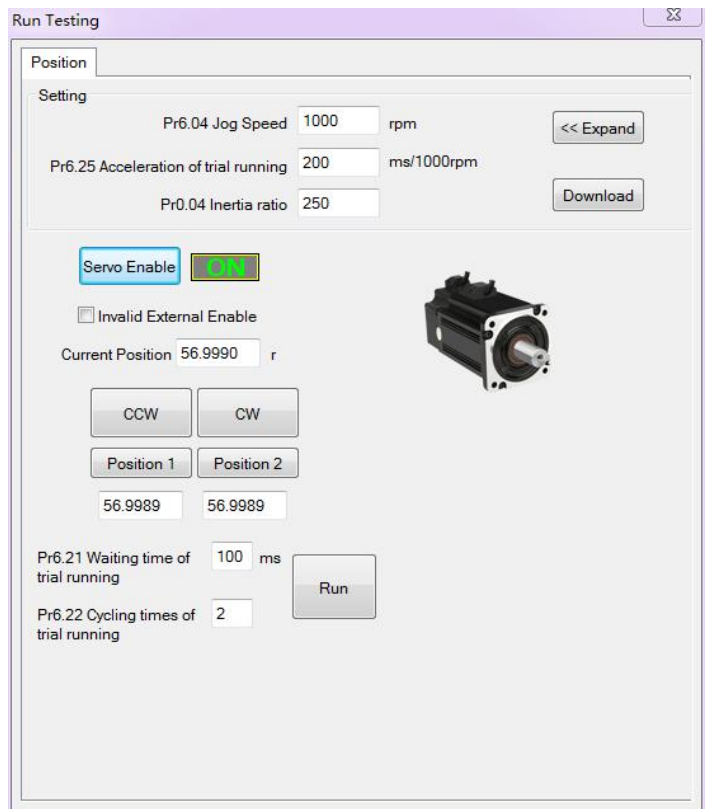

## Control mode setting (Pr0.01)

Pr0.01*	Control Mode Setup	Range	unit	default	Related control mode		
		0 -10	-	0	P	S	T
Set using control mode							
	Setup value	Content		When you set up the combination mode of 3.4.5, you can select either the 1st or the 2nd with control mode switching input(C-MODE).  When C-MODE is open, the 1st mode will be selected. When C-MODE is shorted, the 2nd mode will be selected.			
		1st mode	2nd mode				
	0	Position	-				
	1	Velocity	-				
	2	Torque	-				
	6	Pr-Mode					

Then connect the wire correctly and use controller to check whether motor run normally or not.

## Mode of real-time auto-gain tuning setting (Pr0.02)

Select different operation mode in real-time automatic adjustment mode,

In **Manual** mode(Pr0.02=0), Kp, Ki and other parameters can be set manually. Pr003 is unavailable now .

About how to tune position loop, Ki can be adjusted to a very small value in advance and hold it constant, then enlarge the value of Kp parameter slowly until system oscillation occurs, at this moment enlarge the value of Vi parameter slowly until system oscillation occurs, at this moment the basic adjustment of system is finished.

In **Standard** mode (Pr0.02=1), **it is usually for interpolation movement**. It is unavailable to modify the value of Pr1.00-1.14, just change the value of Pr0.03 , then all values of Pr1.00-1.14 will be changed at the same time .

In **Positioning** mode(Pr0.02=2), **it is usually for point to point movement**. It is unavailable to modify the value of Pr1.00-1.14, just change the value of Pr0.03, then all values of Pr1.00-1.14 will be changed at the same time.

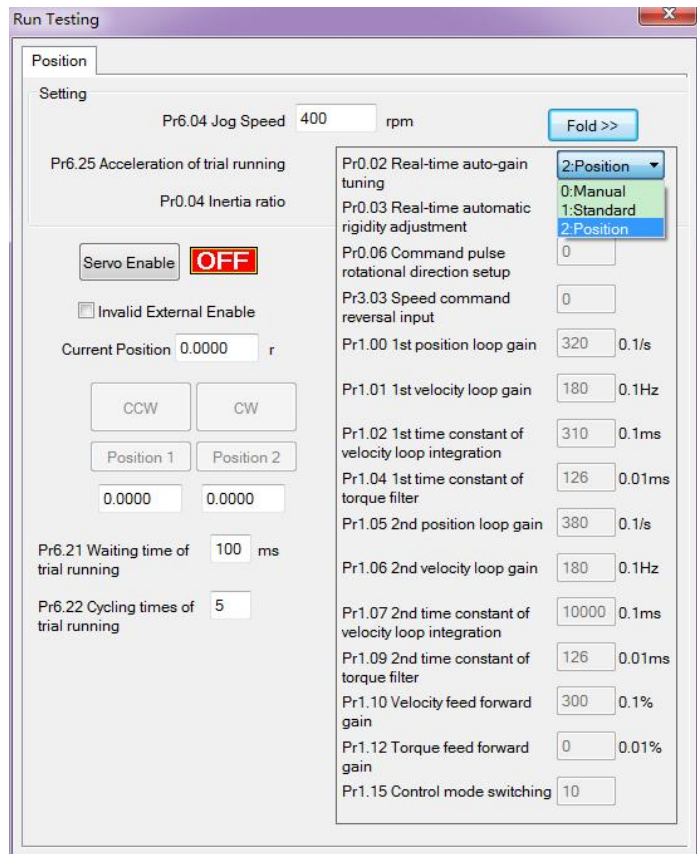

## Performance adjustment—Tuning the inertia ratio(Pr0.04)

It is very important to find the ratio of inertia for one axis, in order to make best performance before setting other parameter (for example, setting PID of position loop or velocity loop).

Connect motor with load if you need to test one axis.

**Make sure the axis can be moved in safe distance, any interference should be avoided to ensure safety and accuracy of testing.**

### Inertia ratio identification

Pre-conditions:

1. Servo disable.
2. Positive limit and negative limit invalid

#### Steps:

- 1 Set the Jog speed Pr6.04, and the setting should not be too large(300~1000rpm is recommend)  
Set the Acc Pr6.25 (50~100 ms/1000rpm is recommend)  
Set the Default Inertia Ratio.

**Download** these settings, then **Servo Enable**.

2. Click “CCW” to make motor run to CCW direction, click “Position 1” to save the position limit 1  
Click “CW” to make motor run to CW direction, click “Position 2” to save the position limit 2  
Click “Run” to start Inertia ratio identification.

3. After finishing, Click“Write”to save the Inertia ratio identification result into NVM.

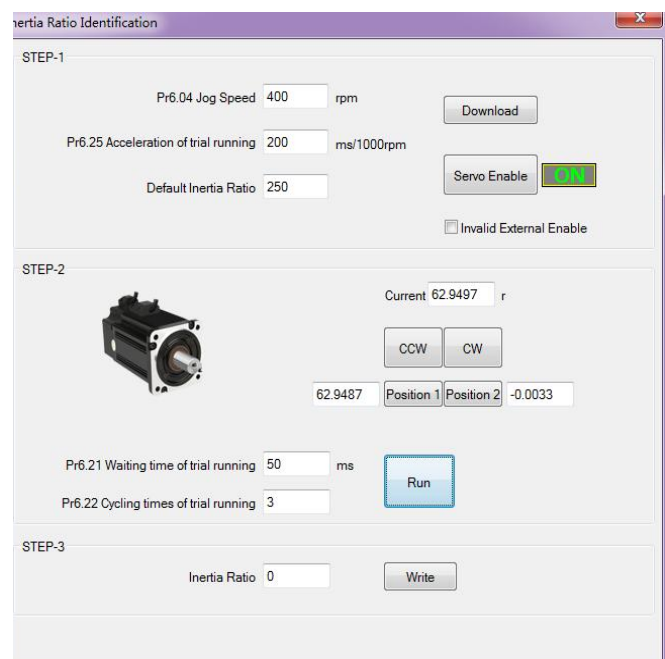

## Performance adjustment—Gain adjustment(Pr0.03)

### The definition of Pr0.03

Pr0.03	Selection of machine stiffness at real-time auto-gain tuning	Range	unit	default	Related control mode		
		50 -81	-	70	P	S	T

You can set up response while the real-time auto-gain tuning is valid.

Low —▶ Machine stiffness —▶ High  
 Low —▶ Servo gain —▶ High

81.80.....70.69.68.....51.50

Low —▶ Response —▶ High

**Notice:** Lower the setup value, higher the velocity response and servo stiffness will be obtained. However, when decreasing the value, check the resulting operation to avoid oscillation or vibration.

Control gain is updated while the motor is stopped. If the motor can't be stopped due to excessively low gain or continuous application of one-way direction command, any change made to Pr0.03 is not used for update. If the changed stiffness setting is made valid after the motor stopped, abnormal sound or oscillation will be generated. To prevent this problem, stop the motor after changing the stiffness setting and check that the changed setting is enabled.

The following figure showing Pr0.02=2, Pr0.03=70, the position error (curve in red) is unacceptable! Keep decreasing value of Pr0.03, then the position error become smaller and smaller.

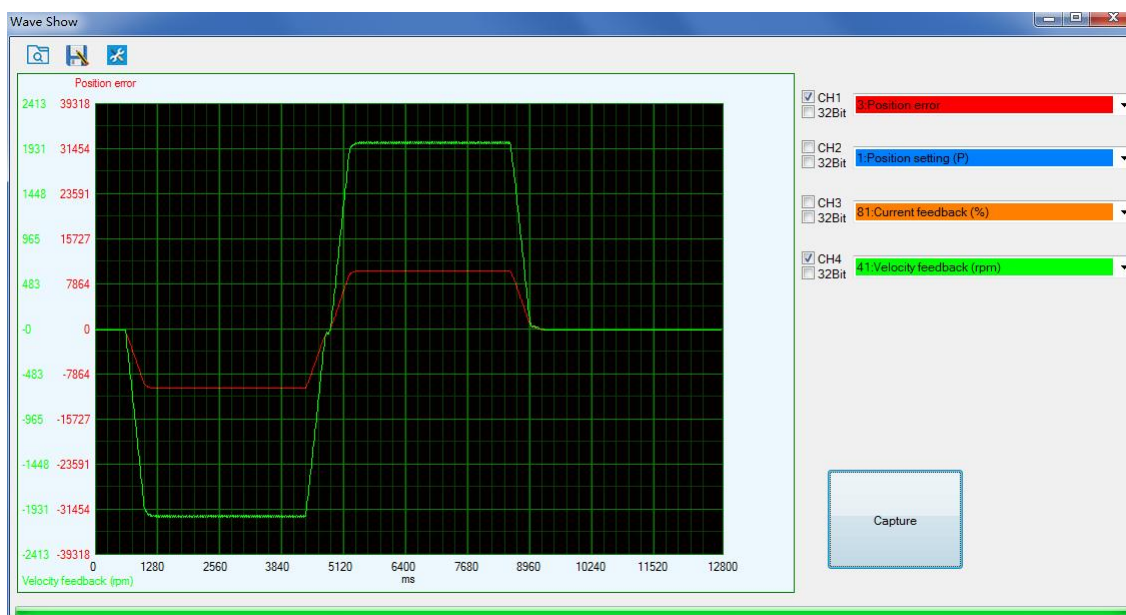



Pr0.03=66

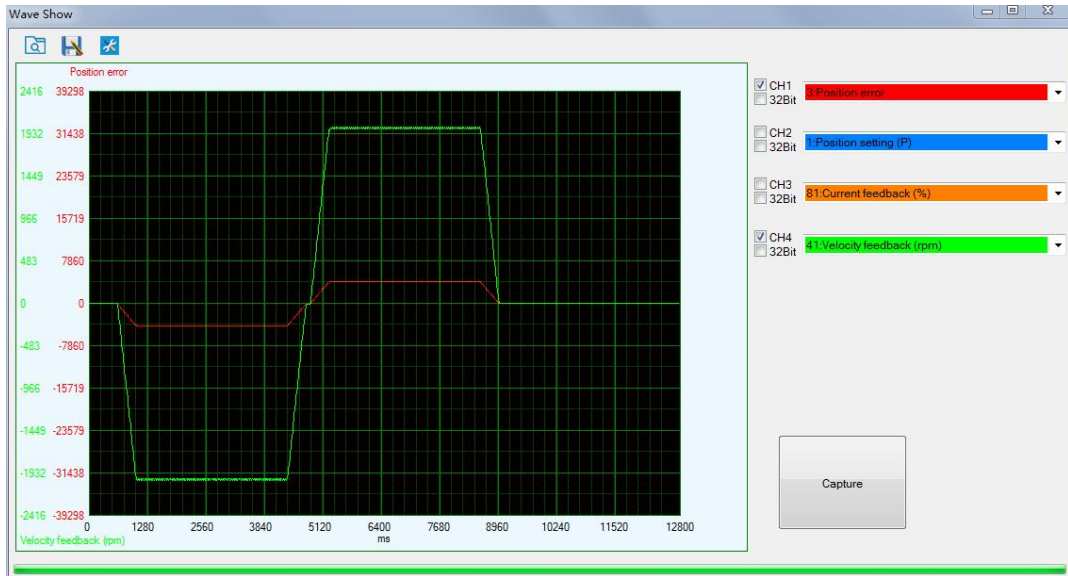

Pr0.03=62

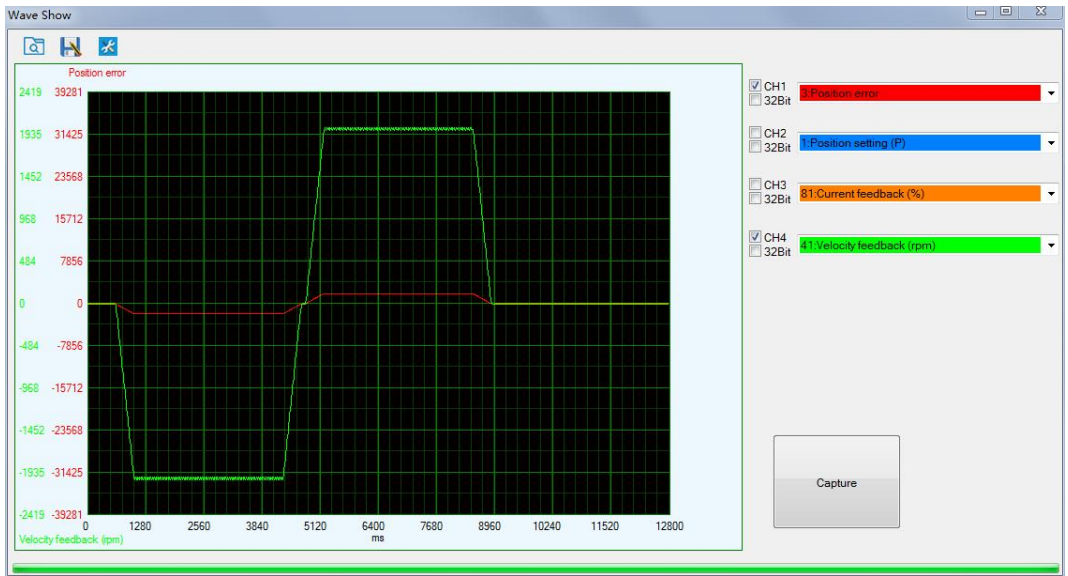

As keep decreasing the value pf Pr0.03, the position loop gain  $K_p$  become bigger and bigger, the integration time constant  $V_i$  become smaller and smaller, the position error become close to zero.  
Pr0.03=61

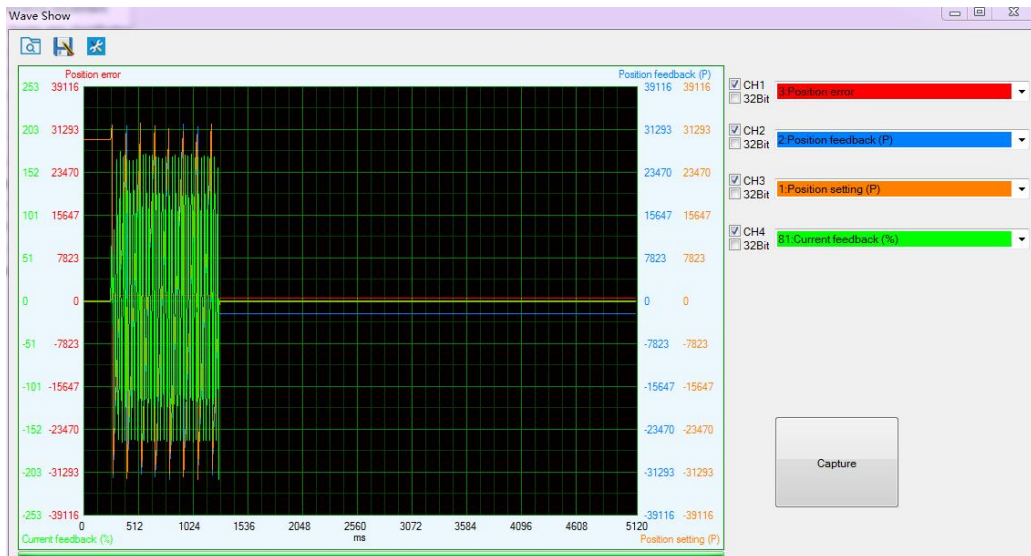

Comm:Online      Servo Disable      Alarm motor vibration

The noise of motor occurs and alarm occurs if the position loop gain becomes bigger, so just make sure there is no noise.

Finally, set Pr0.03=62, the basic setting for position loop is finished in **Position mode**.

## Simple debugging for position control

- **Debugging steps**

- (1) Confirm pulse polarity Pr0.06, command input mode Pr0.07
- (2) Modify Pr0.08 and set a suitable electronic gear ratio, if intend to set non-integral electronic gear ratio, can use Pr0.09 and Pr0.10.
- (3) Set suitable inertia with Pr0.04; suggest increase/decrease the value In multiples of 100.
- (4) Adjust Pr0.03 to be a suitable stiffness value. Suggest to set it from big to small until sharp noise appear
- (5) Each time you modify parameters, pls execute save steps and restart the power.

- **Basic parameter debugging**

Parameters	Range	Details
Pr0.01(Control mode)	0/1/2	Pr0.01=0 for Position Mode
Pr0.02 (Real-time auto configuration)	0/1/2	Pr0.02=0 for <b>Manual</b> mode, Real-time auto-gain tuning function is disabled. Pr0.02=1 for <b>Standard</b> mode, <b>it is usually for interpolation movement</b> . It is unavailable to modify the value of Pr1.00-1.14, just change the value of Pr0.03, then all values of Pr1.00-1.14 will be changed at the same time. Pr0.02=2 for <b>Positioning</b> mode, <b>it is usually for point to point movement</b> . It is unavailable to modify the value of Pr1.00-1.14, just change the value of Pr0.03, then all values of Pr1.00-1.14 will be changed at the same time .
Pr0.03(Machine rigid)	50 -81	Default value is 70, lower the setup value, higher the velocity response and servo stiffness will be obtained.
Pr0.04(inertia ratio)	0—10000	Default value is 250, Pr0.04=( load inertia/rotate inertia)×100%
Pr0.06(Pulse polarity setting)	0/1	Set Pr0.06 to change the rotation direction.
Pr0.07(Pulse input model)	0/1/2/3	Command Pulse Input Mode, set Pr0.07 according to controller signal
Pr0.08(command pulse per motor rotation)	0-8388608	1) If Pr008≠0 , the motor actual turns = pulse number / Pr008 2) If Pr008=0 , Pr0.09 1st numerator of electronic gear and Pr0.10 Denominator of electronic gear become valid.
Pr0.09(numerator of electronic gear)	0-8388608	If Pr008=0 , Pr0.09 1st numerator of electronic gear and Pr0.10 Denominator of electronic gear become valid.
Pr0.10(denominator of electronic gear)	0-8388608	

**Remark:**

1. Default for Pr0.08 pulse per rev is 10000.
2. Electronic gear ratio can be also set by Pr0.09(numerator) and Pr0.10(denominator), Pr0.08 must be set as 0 before that.
3. Input pulse frequency which is higher than 500K can not be identified by driver. Assuming that 10000 ppr, that means corresponding command bandwidth of 3000rpm can reach to 500k. If motor run above 3000 rpm, the pulse per rev must be lower than 10000.



## Position command filter

To make the positional command divided or multiplied by the electronic gear smooth, set the command filter.

Pr2.22	positional command smoothing filter	Range	unit	default	Related control mode	
		0 -32767	0.1ms	0	P	

- Set up the time constant of the 1st delay filter in response to the positional command.
- When a square wave command for the target speed  $V_c$  is applied, set up the time constant of the 1<sup>st</sup> delay filter as shown in the figure below.

Pr2.23	positional command FIR filter	Range	unit	default	Related control mode	
		0 -10000	0.1ms	0	P	

- Set up the time constant of the 1st delay filter in response to the positional command.
- When a square wave command for the target speed  $V_c$  is applied, set up the  $V_c$  arrival time as shown in the figure below.

## Tuning the dynamic tracking performance (Pr0.00) *(optional)*

**Notes:** set Pr0.02=2 if application is **point to point** movement, no need to tune the dynamic tracking performance. set Pr0.02=1 if application is **interpolation** movement, it is very useful to tune the dynamic tracking performance. MFC function is very useful for better dynamic tracking control and contouring cutting.

### Model Following Control (MFC)

As a new control technology, MFC is used to enhance the performance of dynamic tracking for input command, make positioning faster, cut down the tracking error, run more smooth and steady .

There are two different way to use it, one is set Pr0.00 =1, the other is set Pr0.00 as another integer which is more than 10 .

It is very useful for multi-axis synchronous movement and interpolation, the performance will be better if the value of each axis is the same.

Pr0.00	Mode loop gain	Range	unit	default	Related control mode		
		0 -32767	0.1Hz	0	P		

Set up the bandwidth of MFC , it is similar to the response bandwidth

Setup value	Meaning
0	Disable the function.
1	Enable the function , set the bandwidth automatically , recommended for most application .
2-10	Forbidden and reserved .
11-20000	Set the bandwidth manually , 1.1Hz – 2000Hz

**The steps to use this function:**

- a. Choose the right control mode : Pr0.01 = 0
- b. Set up Pr0.02=1 for interpolation movement
- c. Set up the inertia ratio : Pr0.04
- d. Set up the rigidity : Pr0.03
- e. Set up the Pr0.00 :
  - 1) If no multi-axis synchronous movement , set Pr0.00 as 1 or more than 10 ;
  - 2) If multi-axis synchronous movement needed , set Pr0.00 as the same for all the axes .
  - 3) If Pr0.00 is more than 10 , start with 100 , or 150 , 200 , 250 , .... .

**Caution:**

1. Set up the right control mode, the correct inertia of ratio and rigidity firstly .
2. Don't change the value of Pr0.00 when the motor is running, otherwise vibration occurs .
3. Set up a small value from the beginning if using it in manual mode, smaller value means running more smooth and steady, while bigger one means faster positioning.