

一、 PRODUCT INTRODUCTION	1
1. OVERVIEW.....	1
2. PERFORMANCE PARAMETERS.....	2
3. APPLICATIONS	3
二、 ELECTRICAL, MECHANICAL AND ENVIRONMENTAL SPECIFICATIONS.....	1
1. ELECTRICAL SPECIFICATIONS	2
2. OPERATING ENVIRONMENT AND SPECIFICATIONS.....	2
3. MECHANICAL SPECIFICATIONS. (UNIT:MM).....	3
三、 INTRODUCTION TO DRIVER INTERFACE AND WIRING.....	3
1. INTERFACE DEFINITION	3
2. CIRCUIT DIAGRAM OF CONTROL SIGNAL INTERFACE.....	4
3. ONTROL SIGNAL TIMING DIAGRAM	5
四、 INTRODUCTION TO DRIVE STATUS INDICATORS.....	5
1. FAULT DESCRIPTION.....	5
2. MONITORING PARAMETER DESCRIPTION	5
3. DESCRIPTION OF COMMONLY USED FUNCTION CODES.....	5
五、 DRIVER BUTTON PARAMETER SETTING	6
六、 POWER SUPPLY PRECAUTIONS	6
七、 OPEN LOOP, CLOSED LOOP, BRAKE CONTROL SETTINGS	6
八、 BRAKE CONTROL SETTINGS	6
九、 MICROCONTROLLER-MULTI-SEGMENT SETTINGS	7
十、 ORIGIN FUNCTION SEARCH	10
十一、 SPEED MODE	11

十二、 PRODUCT WARRANTY TERMS.....	12
---------------------------------	----

OK2D57ECS

New generation digital display closed loop stepper driver

1.Product introduction

1. Overview

OK2D57ECS is a new closed loop stepper driver developed by our company based on more than ten years of stepper and servo R&D experience. It can used to drive NEMA 23, NEMA 24 closed loop stepper motor. It adapts the latest ARM chip and applied vector closed-loop control algorithm to completely overcome the loss of open-loop stepper motors. At the same time, it can significantly improve the high-speed performance and torque output of the motor, and reduce the heating and low-speed resonance problems of the motor. In addition, when the motor is continuously overloaded, the driver will output an alarm signal, which has the same reliability as the AC servo system. The traditional stepper drive solution is easy to upgrade, and the cost is not much higher than that of the open-loop stepper motor, which is only equivalent to 30-50% of the traditional AC servo system.

2. Performance parameters

- ◆ Built-in microcontroller function can replace PLC in most occasions, significantly reducing user costs.;
- ◆ Internally supports jog mode, open-loop/closed-loop option functions.
- ◆ Built-in smoothing filter function, external input can operate normally

without acceleration or deceleration;

- ◆ Adopts a new 32-bit motor control dedicated ARM smart chip;
- ◆ 4-digit LED digital tube display with 4 button operations, intuitive and easy to operate.;
- ◆ Adopt advanced vector current, speed and position closed-loop control algorithms;
- ◆ The current can be set arbitrarily (within the range of 0--6A);
- ◆ The standard motor comes with a 1000-line high-precision photoelectric or magnetic encoder.;
- ◆ Optocoupler isolation differential signal input, pulse response frequency up to 200KHZ.;
- ◆ Arbitrary microstep setting (200-60000) to meet all occasions;

It has protection functions such as overcurrent, overvoltage, overspeed, overheating, and excessive tracking error;

3. Application:

Suitable for various small and medium-sized automation equipment and instruments, such as: engraving machines, wire stripping machines, marking machines, cutting machines, laser phototypesetting, plotters, CNC machine tools, automatic assembly equipment, etc. Particularly adapt to the applications desired with low noise, low heating, high speed and high precision.

二、Electrical, mechanical and environmental specifications

1. Electrical Specification

Parameters	OK2D57ECS			
	Min	Typical	Max	Unit

Continuous output current	1.0	-	6.0	A
Input Voltage	24	-	48	VDC
Logic Signal Current	7	10	20	mA
Power			150	W
Pulse input frequency	0	-	200	kHz
Isolation resistance	500			MΩ
Digital output port logic current			100	mA
Digital output port voltage resistance	-	-	24	V

2. Operating Environment and other Specifications

Cooling	Natural Cooling or Forced cooling	
Operating environment	Environment	Avoid dust, oil fog and corrosive gases
	Ambient Temperature	0°C—50°C
	Humidity	40—90%RH
	Vibration	10~55Hz/0.15mm
Storage Temperature	-20°C—+65°C	
Weight	About 300g	

3. Mechanical Specifications: (unit: mm [1inch=25.4mm])

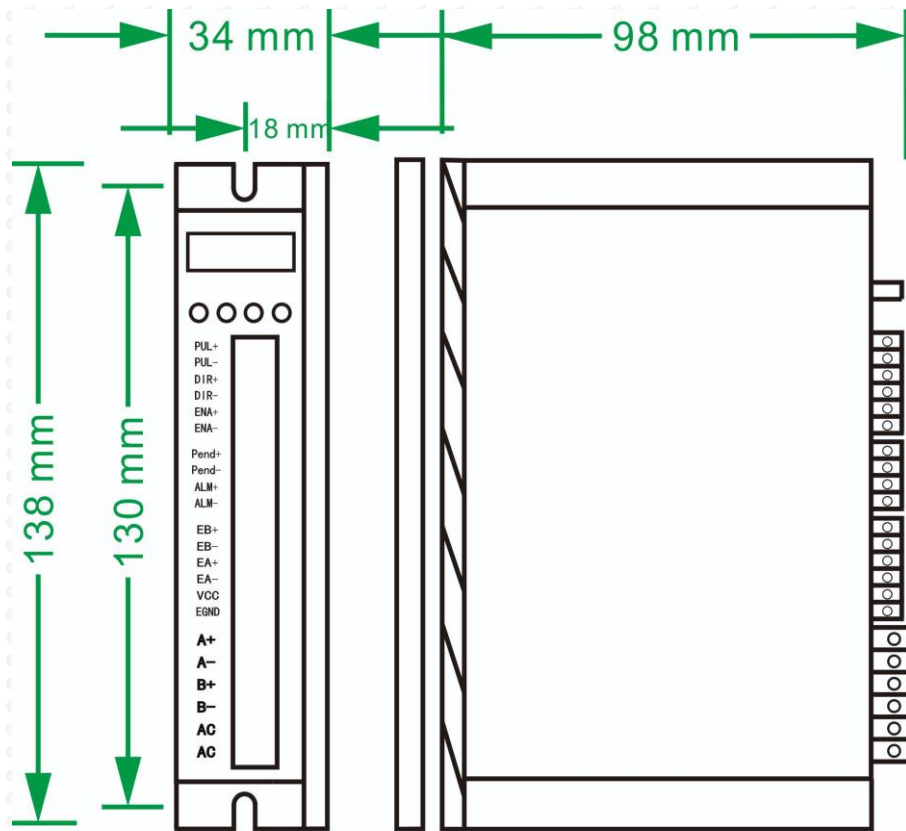

Front View

Side View

4. Methods of quick heat dissipation

- (1) The reliable operating temperature of the driver is usually within 60°C, and the operating temperature of the motor is within 80°C;
- (2) When installing the driver, please install it upright on its side to form strong air convection on the surface of the radiator. If necessary, install a fan close to the driver to force heat dissipation to ensure that the driver operates within a reliable temperature.

3.Introduction to driver interface and wiring

1. Interface definition

Motor and power input ports

PIN	Mark	Neme	Lead color	
1	A+	Motor Phase A+	White	Red
2	A-	Motor Phase A-	Green	Green
3	B+	Motor Phase B+	Blue	Yellow
4	B-	Motor Phase B-	Black	Blue
5	+VDC	Input DC voltage positive pole	24-48VDC Pay attention to the direction	
6	GND	Input DC voltage negative pole		

Note: The closed-loop motor wiring must strictly follow the color definitions and cannot be wired at will.

Encoder: Encoder signal input port

Pin	Name	Description	Note
-----	------	-------------	------

1	EB+	Encoder channel B+ input	YELLOW
2	EB-	Encoder channel B- input	Green
3	EA+	Encoder channel A+ input	Black
4	EA-	Encoder channel A- input	Blue
5	VCC	Encoder power supply +5V input	RED
6	EGND	Encoder power ground	White

Control Signal: Control signal port

PIN	Name	Description	Note
1	PUL+	Pulse positive input	The signal source is universal from +5V to 24V, no need to connect resistors in series.
2	PUL-	Pulse negative input	
3	DIR+	Direction positive input	The signal source is universal from +5V to 24V, no need to connect resistors in series.
4	DIR-	Direction negative input	
5	ENA+	Motor enable positive input	When this signal is valid, the motor is in a free state and does not lock the machine.
6	ENA-	Motor enable negative input	
9	ALM+(BRK+)	Alarm/brake signal positive output	P-11 Setup to select alarm/brake
10	ALM-(BRK-)	Alarm/brake signal negative output	

2. Control signal interface circuit diagram

Control signal input and output interface circuit diagram, as shown in the figure.

(1) Input signal connection

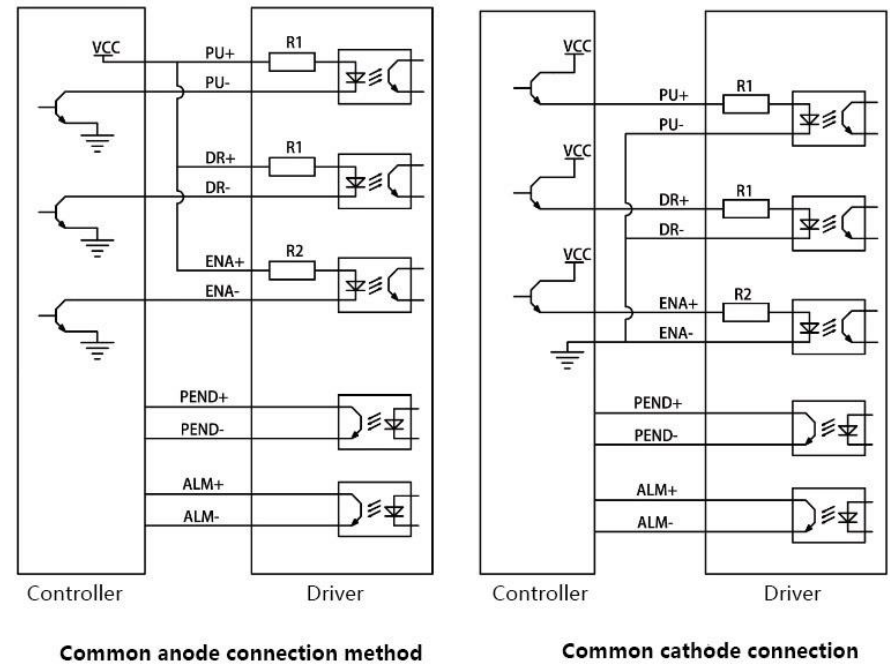

Special note: This driver supports 5V-24V and does not require a series resistor!

(2) When using differential input, please wire as shown below.

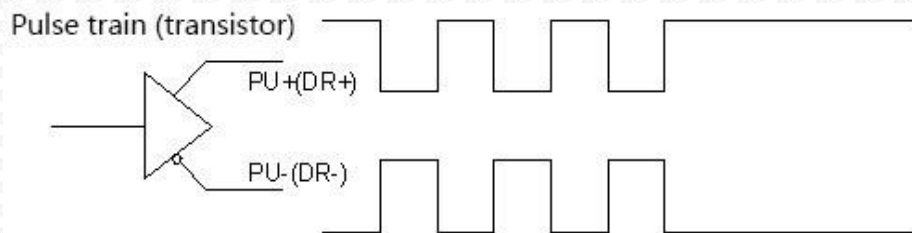

Pic 3(a) Differential mode control signal interface wiring diagram

3. Control signal timing diagram

In order to avoid some malfunctions and deviations, PUL, DIR and ENA should meet certain requirements, as shown in Figure 4 below:

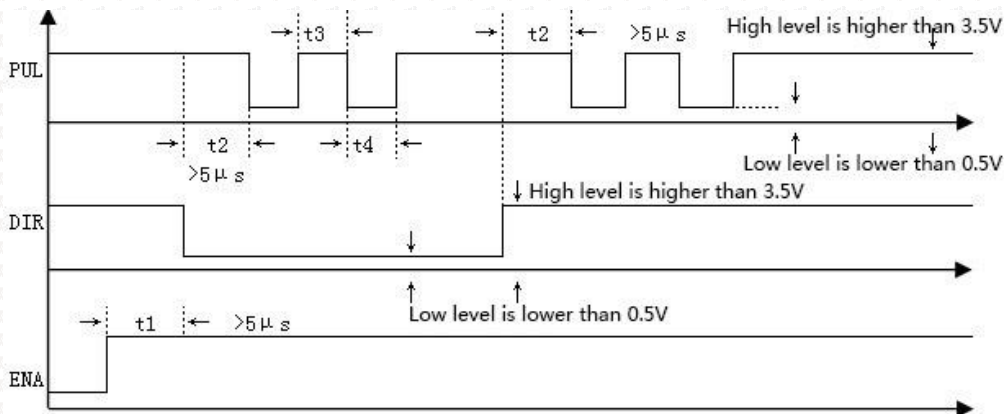

Picture 4 Timing diagram

Note:

- (1) t1: ENA must be ahead of DIR by at least 5ms. Usually, ENA+ and ENA- are NC (not connected).
- (2) t2: DIR must be ahead of PUL effective edge by 5ms to ensure

correct direction;

- (3) t3: Pulse width not less than 2.5ms.
- (4) t4: Low level width not less than 2.5ms.

4. Introduction to drive status indicators

1. Fault description

Number	Error code	Fault description	Troubleshooting
1	Er01	hardware malfunction	Need to return to factory for testing
2	Er02	Motor overcurrent	Check whether the motor is short-circuited or reduce the current
3	Er03	Drive overvoltage	Check whether the input voltage is too high
4	Er04	Driver undervoltage	Check whether the input voltage is too low
5	Er05	Location out of tolerance	The motor is overspeeding, increase the current and voltage appropriately.

2. Parameter monitoring instructions

PIN	Function code	Function Description	Function introduction
1	L-00	Speed	Monitor the current speed, voltage, and current to check whether the drive is working normally and resolve any
2	L-01	Voltage	
3	L-02	A phase current	
4	L-03	B phase current	

			abnormalities in time!
5	L-04	Following error	
6	L-05	Number of received pulses	Check the number of received pulses in real time to determine whether the motor has lost step.
7	L-06	Motor feedback pulse number	
8	L-08	Software version number	The bigger the number, the newer the version

Note: L-01 What is displayed is the DC voltage inside the driver;

3. Description of commonly used function codes

Number	Parameter settings	Function code	Function Description
1	Number of subdivided pulses	P-00	200-60000 can be set at will, factory default setting is 1600
2	Closed loop holding current	P-01	1.0-6.0, factory default 2.0A
3	Jog operation	P-06	Enter into JOG, Press ▲ ▼ Jog
4	Motor direction	P-12	0 reverse, 1 forward
5	Reset	S-20	Set to 1 to restore factory settings

5.Driver button parameter settings:

The driver's operation panel consists of 4 LED digital displays and 4 buttons M, ▲, ▼, and ◀, which are used to display various system status, parameter settings, etc.

Button function description table

Button	Function Description
M	Function selection: P parameter, S parameter, L parameter switching
▲	When the value changes: +1, long press to increase quickly. In jog mode: press and hold the motor to rotate forward
▼	When the value changes: -1, press and hold to quickly reduce. In jog mode: press and hold the motor to reverse
◀	<ol style="list-style-type: none"> Press and hold this button for 0.5 seconds to enter parameter setting When setting parameters, press once and shift to the left once After the setting is completed, press and hold this button for 0.5 seconds to confirm that the setting is successful and return to the current function code. In case of a fault, press and hold this button for 2 seconds to reset the fault.

After the driver is powered on, the enable display is run, indicating that the motor is powered on and the driver is working normally. When the motor enable is turned off, stop is displayed.

Complete parameter menu:

The driver provides 2 sets of parameters for user operation. The P parameter is used to set several general parameters of the driver. Parameter value (such as microstep resolution, lock current, motor type, etc.), S parameter is used to set the performance parameter index value of the driver.

P parameter function table

Parameter	Name	Parameter range	Factory default	Description
P-00	Microstep resolution option	200~60000	1600	Any microstep resolution settings
P-01	Closed loop holding current	1.0~6.0	2.0	Motor load setting current
P-02	low speed current	1.0~6.0	4.0	Generally do not change
P-03	Closed loop peak current	6.0~9.0	8.0	Generally do not change
P-04	Open loop mode operating current	1.0~8.0	4.0	Generally do not change
P-05	Open loop mode automatic semi-flow	10~90%	50%	Generally do not change
P-06	Jog operation	JOG		Press ▲, ▼ to move forward and reverse
P-07	Jog speed	0~100	100	Jog speed
P-08	pulse mode	0~1	0	0-pulse+ direction, 1-AB Orthogonal
P-09	operating mode	0~1	0	0: pulse mode, 1: Internal position mode 2: speed mode
P-10	ALM alarm	0~1	1	0: Normally

	polarity Output settings			closed, 1: Normally open
P-11	ALM function selection	0~1	0	0: Alarm Output, 1: Brake control 2: Z pulse
P-12	Motor running direction	0~1	0	0 reverse, 1 forward
P-13	ENA enable control	0~1	1	0: Low level enable 1: High level enable
P-14	Pulse input pin filter	0~5	0	The larger the number, the stronger the filtering 0 --> 4MHZ, 5 --> 150KHZ
P-16	Anti-disturbance time	0~1000ms	1000	Generally do not change
P-17	Tracking error alarm threshold	0~32000	4000	Generally do not change
P-18	Open and closed loop mode selection	0~1	1	0 open loop, 1 closed loop
P-25	Smoothing filter enabled	0~1	0	0 is not enabled, 1 is enabled (important)
P-26	Position loop	0~10000	150	Adjust this

	smoothing filter			parameter if the input pulse has no acceleration or deceleration.
P-98	Undervoltage, overvoltage alarm	0~1	0	0 alarm, 1 shield
P-99	Position loop acceleration and deceleration time	0~1000	8	When starting and stopping quickly, adjust this parameter

Special note: The bold yellow shading in the P parameter table is the commonly used function settings. The rest generally do not need to be changed. Just restore the factory settings to S-20 and set it to 1!

After setting the function, power off and restart is required!

S parameter function table

Parameter	Name	Parameter range	Factory default	Description
S-19	Encryption	2020	0	Only when 2020 is set can other parameters of S be modified (the data of 2020 is still displayed as 0)
S-01	Encoder resolution settings	4000	4000	1.8°4000; 0.9°2000
S-03	Current loop proportional gain P	1~32000	1500	The larger the setting value, the higher the gain and the greater the

				stiffness.
S-04	Current loop integral gain I	1~32000	200	The smaller the setting value, the faster the integration speed, the stronger the system's resistance to deviations, and the greater the rigidity. If it is too small, it will easily cause overshoot.
S-05	Position loop proportional gain KP	1~32000	2500	The larger the setting value, the higher the gain, the greater the stiffness, and the faster the position tracking. But a value that is too large may cause motor oscillation or overshoot.
S-06	Position loop integral gain KI	1~32000	500	
S-07	Position ring KD	1~32000	100	
S-08	Position loop KVFF	1~32000	30	The larger the setting value, the faster the tracking speed and the greater the rigidity. It is strongly recommended to use the factory parameters and do not modify them at will.

S-20	Reset	0~1	0	Restore factory settings after setting to 1
------	-------	-----	---	---

Special note: The driver's factory default current loop parameters, position loop parameters, etc. are the optimum parameters for the matching motor, and customers generally do not need to modify them. If the customer's application environment is special, the parameters with * can be modified under the guidance of professionals to achieve the best use results.

After setting the function, power off and restart is required!

Case 1: The user starts and stops quickly, brakes suddenly, and the motor shakes unstable when stopped. Set S-05 to 2000 and S-07 to 400 to achieve satisfactory results!

6. Power supply precautions

The DC input voltage is DC24V~50V, and the power supply power is not higher than 150W. The higher the voltage input and the larger the current setting, the greater the motor torque and the better the high-speed performance. However, the motor generates more heat. In principle, as long as it meets the use, the smaller the current setting. The better.

Please note:

- 1) When wiring, pay attention to strictly follow the colors of the motors;
- 2) The driver must not be connected to 220V. The driver is DC, so pay attention to the direction;
- 3) The encoder power supply is provided by the driver and does not need to be powered separately;
- 4) The control signal wire and the motor phase wire cannot be entangled together, and it is better to add a shielding layer to the signal wire;

7. Open loop and closed loop settings

This driver is a closed-loop driver can drive Nema 34 (86 x 86) stepper motor which must be equipped with a 1000-line encoder. The motor's operating performance can be greatly improved by more than 30% compared to open-loop.

When an unexpected situation occurs, such as encoder failure or poor contact of the encoder line, you can set P-18 to 0 (need to power off and restart) and turn on the open-loop mode to solve customer problems to the greatest extent.

8. Brake control settings

When the motor is braked, the brake signal is controlled by the ALM alarm output pin.

Set P-11 to 1, P-85 power-on brake release delay time, P-86 alarm power-off delay time!

Press and hold left arrow to save

Wiring method for motor with brake:

Since the brake coil will generate a relatively large surge current when it operates, if the brake coil is directly connected to the output port of the driver, the optocoupler at the driver output port will be damaged, so a relay must be used as a relay control. Since the brake coil and relay are both inductive loads, it is recommended to add a freewheeling diode. Do not connect the diode in the opposite direction when wiring.

It is recommended that customers choose solid-state relays, then you don't need to use freewheeling diodes. The advantages of solid-state relays are: fast response, no need for freewheeling diodes, and no sound when powered on.

The wiring of the brake and relay is as shown below:

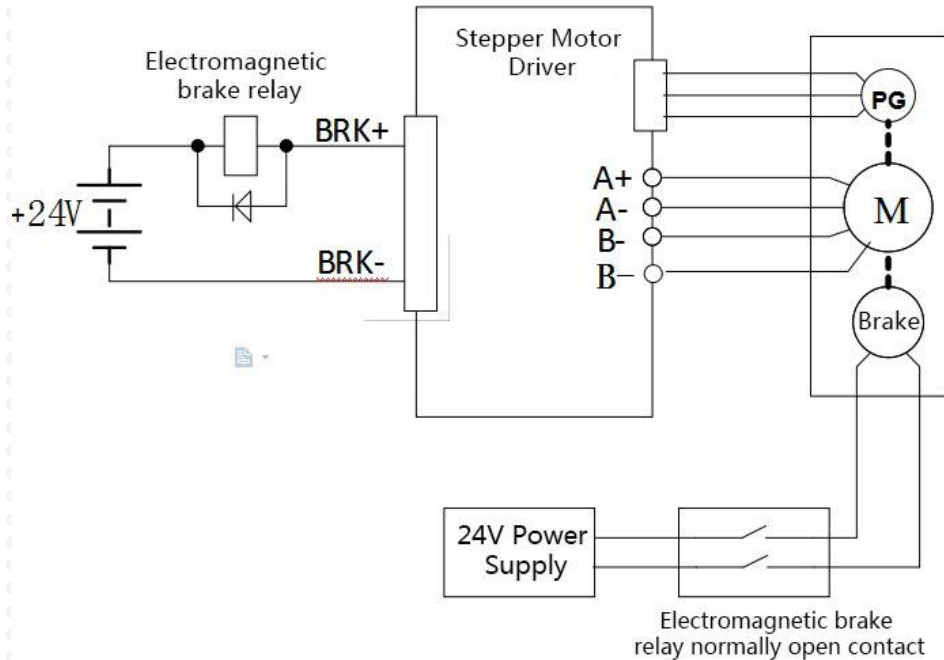

9. Microcontroller-multi-segment setting instructions

Multi-segment position means that the driver stores 8-segment position instructions internally, and the displacement, maximum operating speed, and acceleration and deceleration time of each segment can be set separately. The waiting time and connection method between each section can also be selected according to actual needs.

The time interval between each group of positions is determined by P-66~P-73, and

the number of cycles is determined by P-49. If the time interval is 0, it will switch to the next group of operations when the speed is the highest. If P-49=0 at this time, the cycle will continue. If you need to trigger the operation through the input terminal each time after the multi-segment setting is completed, instead of running according to the set time interval, please set P-19 to 1.

User parameters		Location command source
P-09	1	Multiple location settings

User parameters		Location command source
P-19	0	Segment continuous running mode, trigger once and execute everything
	1	Segment single trigger mode, trigger once and execute a segment sequentially

Multi-position position external input trigger mode selection.

User parameters	Function	
P-23	0	high level signal
	1	Rising edge signal factory default 1
	2	Falling edge signal
	3	low level signal

The multi-segment position mode can be set to relative mode and absolute mode according to P-28.

User parameters		significance
P-28	0	Relative mode: Each time it is triggered, the forward and reverse speeds are increased or decreased by the original command pulses at the current position according to the original command.
	1	Absolute mode: Each time it is triggered, it will rotate forward or reverse to the absolute position of the given pulse according to the absolute value of the current given speed.

Absolute type and relative type are widely used. Users can easily complete periodic operation by using the table above.

Multi-segment position mode internal trigger operation					
		Predetermined area	Set unit	Factory default	Effective method
P-29	0: Not triggered		G	0	Effective immediately
	1: trigger				
P-29 Set to 1 to trigger the multi-segment position mode. This parameter will automatically return to 0 after triggering.					

Internal position PUL function		Location command source
P-39	0	PUL triggers emergency pause function and continues operation after restart
	1	PUL triggers the emergency stop function and resets to run from the first stage after restarting.

The number of segments to run in multi-segment					
		Predetermined area	Set unit	Factory default	Effective method
P-48					
		1~8	G	2	Effective immediately

Number of internal position loops of multiple segments					
		Predetermined area	Set unit	Factory default	Effective method
P-49					
		0~30000	G	0	Effective immediately

External port function description

PUL	Input a stop signal, and it needs to be terminated or paused every time it runs (select P-39). Please connect PUL+ to 24V and PUL- to 0V.
DIR	Input the start signal, and each trigger starts continuous operation or single operation. Please connect DIR+ to 24V and DIR- to 0V.

DIR pin filter time					
		Predetermined area	Set unit	Factory default	Effective method
P-88					
		0~3000	ms	0	Effective immediately

The 8-segment position inside the multi-segment position mode can have different acceleration and deceleration settings according to actual needs. The relevant function codes are as follows:

P-30	Position 1 acceleration and deceleration time			
	Predetermined area	Set unit	Factory default	Effective method
	0~32000	ms	100	Effective immediately
P-31	Position 2 acceleration and deceleration time			
	Predetermined area	Set unit	Factory default	Effective method
	0~32000	ms	100	Effective immediately
P-32	Position 3 acceleration and subtraction time			
	Predetermined area	Set unit	Factory default	Effective method
	0~32000	ms	100	Effective immediately
P-33	Position 4 acceleration and subtraction time			
	Predetermined area	Set unit	Factory default	Effective method
	0~32000	ms	100	Effective immediately
P-34	Position 5 acceleration and deceleration time			
	Predetermined area	Set unit	Factory default	Effective method
	0~32000	ms	100	Effective

				immediately
P-35	Position 6 acceleration and subtraction time			
	Predetermined area	Set unit	Factory default	Effective method
	0~32000	ms	100	Effective immediately
P-36	Position 7 acceleration and subtraction time			
	Predetermined area	Set unit	Factory default	Effective method
	0~32000	ms	100	Effective immediately
P-37	Position 8 acceleration and subtraction time			
	Predetermined area	Set unit	Factory default	Effective method
	0~32000	ms	100	Effective immediately

The 8-segment position inside the multi-segment position mode can be set at different speeds according to actual needs. The relevant function codes are as follows:

P-40	Position 1 running speed			
	Predetermined area	Set unit	Factory default	Effective method
	0~2000	r/min	100	Effective method
P-41	Position 2 running speed			
	Predetermined area	Set unit	Factory	Effective

			default	method
	0~2000	r/min	100	Effective immediately
P-42	Position 3 running speed			
	Predetermined area	Set unit	Factory default	Effective method
	0~2000	r/min	100	Effective immediately
P-43	Position 4 running speed			
	Predetermined area	Set unit	Factory default	Effective method
	0~2000	r/min	100	Effective immediately
P-44	Position 5 running speed			
	Predetermined area	Set unit	Factory default	Effective method
	0~2000	r/min	100	Effective immediately
P-45	Position 6 running speed			
	Predetermined area	Set unit	Factory default	Effective method
	0~2000	r/min	100	Effective immediately
P-46	Position 7 running speed			
	Predetermined area	Set unit	Factory default	Effective method
	0~3000	r/min	100	Effective immediately
P-47	Position 8 running speed			

	Predetermined area	Set unit	Factory default	Effective method
	0~3000	r/min	100	Effective immediately

The 8-segment position in the multi-segment position mode can be set to continuous operation according to actual needs, that is, a multi-segment position cycle, in which the position, acceleration and deceleration time and interval time of each position can be set according to different needs. The relevant function codes are as follows:

P-50	Position 000 given position			
	Predetermined area	Set unit	Factory default	Effective method
	-2147483647~+2147483647	G	0	Effective method
P-52	Position 001 given position			
	Predetermined area	Set unit	Factory default	Effective method
	-2147483647~+2147483647	G	0	Effective method
P-54	Position 010 given position			
	Predetermined area	Set unit	Factory default	Effective method
	-2147483647~+2147483647	G	0	Effective method
P-56	Position 011 given position			
	Predetermined area	Set unit	Factory default	Effective method

	-2147483647~+2147483647	G	0	Effective method
P-58	Position 100 given position			
	Predetermined area	Set unit	Factory default	Effective method
	-2147483647~+2147483647	G	0	Effective immediately
P-60	Position 101 given position			
	Predetermined area	Set unit	Factory default	Effective method
	-2147483647~+2147483647	G	0	Effective method
P-62	Position 110 given position			
	Predetermined area	Set unit	Factory default	Effective method
	-2147483647~+2147483647	G	0	Effective method
P-64	Position 111 given position			
	Predetermined area	Set unit	Factory default	Effective method
	-2147483647~+2147483647	G	0	Effective method
P-66	Interval time after the end of segment 1			
	Predetermined area	Set unit	Factory default	Effective method
	-32000~+32000	ms	1000	Effective method
P-67	Interval time after the end of segment 2			
	Predetermined area	Set unit	Factory	Effective

			default	method
	-32000~+32000	ms	1000	Effective method
P-68	Interval time after the end of segment 3			
	Predetermined area	Set unit	Factory default	Effective method
	-32000~+32000	ms	1000	Effective method
P-69	Interval time after the end of segment 4			
	Predetermined area	Set unit	Factory default	Effective method
	-32000~+32000	ms	1000	Effective immediately
P-70	Interval time after the end of segment 5			
	Predetermined area	Set unit	Factory default	Effective method
	-32000~+32000	ms	1000	Effective immediately
P-71	Interval time after the end of segment 6			
	Predetermined area	Set unit	Factory default	Effective method
	-32000~+32000	ms	1000	Effective immediately
P-72	Interval time after the end of segment 7			
	Predetermined area	Set unit	Factory default	Effective method
	-32000~+32000	ms	1000	Effective immediately
P-73	The interval after the end of segment 8			

	Predetermined area	Set unit	Factory default	Effective method
	-32000~+32000	ms	1000	Effective immediately

Origin search selection				
	Predetermined area	Set unit	Factory default	Effective method
P-74	0: Not looking for the origin 1: Automatically find the origin when turning on the machine 2: I/O port triggers to find the origin	G	0	Effective immediately

Function	PIN
I/O trigger signal	Enable terminal
ORGP signal	Pulse terminal

10.Origin function search

1. Features

2. When using the origin return function, you can use the input contact ORGP (external detector input terminal) as the origin reference point, and you can use forward search or reverse search.

3. User parameter settings

Parameter name	Function	Note
P-75=H□□□0	Reverse to find the origin	
P-75=H□□□1	Turn forward to find the origin	
P-75=H□□1□	Use the input terminal ORGP as the origin reference point to search.	
P-75=H□0□□	After reaching the origin reference point, decelerate and stop.	
P-75=H□1□□	After reaching the input terminal ORGP, use the opposite direction to find the rising edge of the input terminal ORGP at the second speed as the origin.	

P-76	Origin/mechanical origin search first speed			
	Predetermined area	Set unit	Factory default	Effective method
	0~2000	0.1r/min	500	Effective immediately
P-77	Origin/machine search second speed			
	Predetermined area	Set unit	Factory default	Effective method
	0~1000	0.1r/min	200	Effective immediately
P-78	Origin search offset pulse number			
	Predetermined area	Set unit	Factory default	Effective method
	-32000~+32000	G	0	Effective immediately

11、Speed mode

Speed mode is mostly used in the precision CNC machining industry. Users can select the mode through P-09 and make different settings according to different occasions.

User parameter settings

Digital setting refers to storing the set speed value through function code P-93 or P-94 or P-95 and using it as a speed command.

(1) Digital given speed mode

There are two application methods for digital given speed mode: the first is for the user to set different speed command values in the P-93 or P-94 or P-95 function code before making an action, and then pass the pulse, Direction The terminal performs speed switching; the second is to use communication methods to change the value of the function code.

A: User related parameters

User parameters		Speed command source		
P-09	2	Digital given		
P-93	Speed command keyboard setting value 1			
	Predetermined area	Set unit	Factory default	Effective method
	0~±4000	r/min	100	Effective immediately
P-94	Speed command keyboard setting value 2			
	Predetermined area	Set unit	Factory default	Effective method
	0~±4000	r/min	200	Effective immediately
P-95	Speed command keyboard setting value 3			
	Predetermined area	Set unit	Factory default	Effective method
	0~±4000	r/min	300	Effective immediately

B: Input signal setting, use the following input signals to switch the operating speed.

Signal name	Name	Function
Digital given speed selection 1	Pulse terminal	Digital given speed selection
Digital given speed selection 2	Direction terminal	

C: Digital given speed operation

Pulse terminal	Direction terminal	
OFF	OFF	0: Zero speed
OFF	ON	P-93: Setting value 1 speed
ON	OFF	P-94: Setting value 2 speed
ON	ON	P-95: Setting value 3 speed

If external terminals are not needed, it will run automatically after power-on. Set P-96 to 1, and then the speed at this time is specified by P-93.

Command ramp function settings

The ramp function control function refers to converting a large-changing speed command into a relatively smooth constant acceleration and deceleration speed command, that is, by setting the acceleration and deceleration time to achieve the purpose of controlling acceleration and deceleration. In the speed control mode, if the given speed command changes too much, the motor will jump or vibrate violently. If the acceleration and deceleration time of the soft start is increased, the motor can start smoothly and avoid the above situation. Mechanical parts are damaged.

User parameter settings

P-89	Acceleration time			
	Predetermined area	Set unit	Factory default	Effective method
	1~30000	ms	200	Effective immediately
P-90	Deceleration time			
	Predetermined area	Set unit	Factory default	Effective method
	1~30000	ms	200	Effective immediately

S-curve smoothing function

During the acceleration and deceleration process, since acceleration and deceleration changes such as starting and stopping will cause impact, it is necessary to add an S-curve acceleration and deceleration command to the speed command, that is, by adding an arc to the acceleration and deceleration slope to make the servo motor run more smoothly.

(1) User parameter settings

P-91	S-curve deceleration time			
	Predetermined area	Set unit	Factory default	Effective method
	1~12000	ms	100	Effective immediately
P-92	S Curve start flag			
	Predetermined area	Set unit	Factory default	Effective method
	0: Does Switch on 1: Switch on	G	0	Effective immediately

12、Product warranty terms

1. One year warranty

Our Company warrants its products against defects in materials and workmanship for a period of 12 months from shipment out of factory. During the warranty period, We will either, at its option, repair or replace products which proved to be defective.

2. Not covered by warranty

The above warranty does not extend to any product damaged by reasons of improper or inadequate handlings by customer, improper or inadequate customer wirings, unauthorized modification or misuse, or operation beyond the electrical specifications of the product and/or operation beyond environmental specifications for the product.

3. Maintenance process

If it is necessary to repair the product, it will be handled according to the following process:

- (1) Before shipping, you need to call the agent to obtain the return permit number.;
- (2) A written description is attached with the product, explaining the fault phenomenon of the drive being returned for repair; the voltage, current and usage environment when the fault occurred; and the name, phone number and mailing address of the contact person.
- (3) Please pay the postage first and send it to the company's location or designated repair point. The company refuses to accept any express freight collect.

4. Warranty limitations

We make no other warranty, either expressed or implied, with respect to the product. We specifically disclaim the implied warranties of merchantability and fitness for a particular purpose. Some jurisdictions do not allow limitations on how long and implied warranty lasts, so the above limitation or exclusion may not apply to you. However, any implied warranty of merchantability or fitness is limited to the 12-month duration of this written warranty.

5. Maintenance requirements

When returning for repair, please fill in the "Maintenance Report" truthfully to facilitate repair analysis.