

User Manual for E6 Series Servo Driver

Driver Parts Name

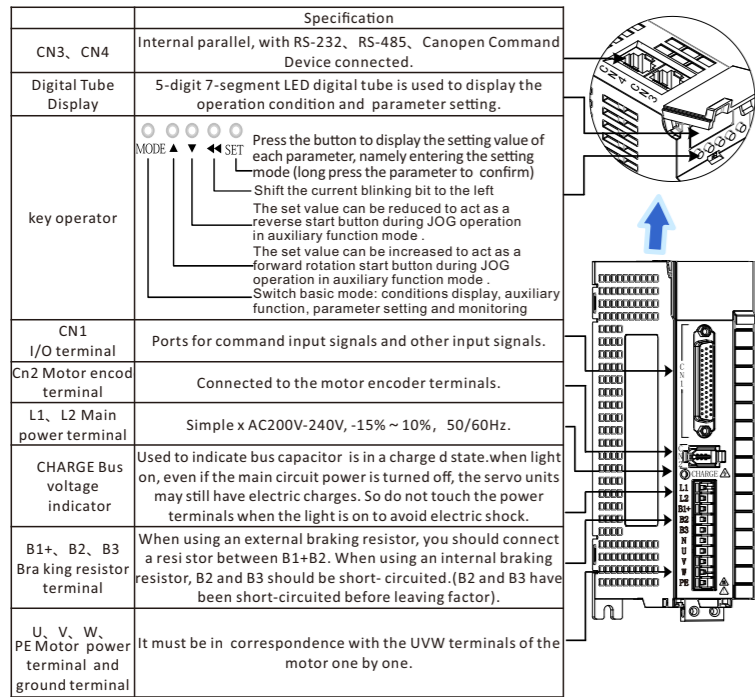

Braking resistor related specifications

Model Type	Built-in braking resistor specifications		Min. Allowed Resistance (Ω)	Max. Braking Energy Absorbed by Capacitor (J)
	Resistance (Ω)	Power(W)		
Single phase 220V	E6-200RS	-	50	9
	E6-400RS	-	45	18
	E6-750RS	50	50	26
	E6-1000RS	50	50	26

Product Specification

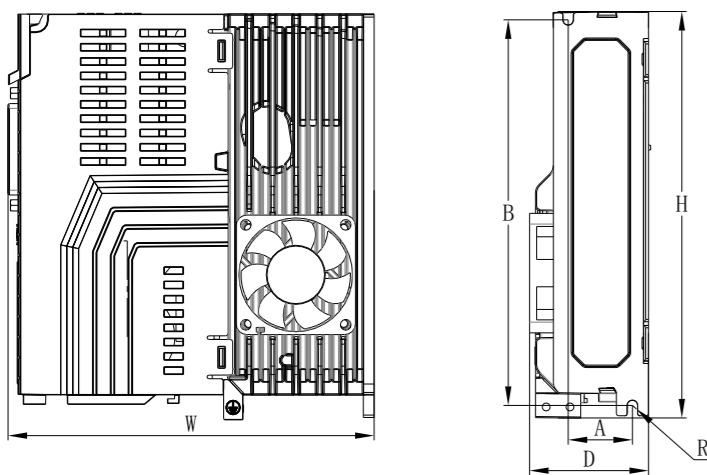

Item	Specification				
	E6 Series	200RS	400RS	750RS	1000RS
Dimension	A(mm)	27			
	B(mm)	162			
	W(mm)	154			
	H(mm)	171			
	D(mm)	51			
	R(mm)	2			
	W(kg)	0.9			
Basic Specifications	Input Power		Single phase AC200V-240V, -15%~10%, 50/60Hz		
	Temperature	Ambient Temperature	0+55°C(from 45°C~to 55°C,keep average load rate within 80%) no freezing		
		Preservation of Ambient Temperature	-20~65°C		
	Humidity	Ambient Humidity	below 20~85%RH (no condensation)		
		Preservation of Ambient Humidity	below 20~85%RH (no condensation)		
	Use and Preservation of Ambient Air		indoor (no direct sunlight), no corrosive gas, flammable gas, oil mist, dust		
	Altitude		below 1000m		
	Vibration		below 5.8m/s ² [0.6G] 10~60Hz(do not use continuously at resonance frequency)		
	Dielectric Withstand Voltage		AC1500V between primary and FG for 1 minute		
	Control Method		three-phase PWM converter sine wave drive		
Control Signal	Encoder Feedback		17bit、23bit (functions as a multi-turn absolute encoder after adding a battery)		
	Input	Input	9-way input (DC24V optocoupler isolation) function switching according to the control mode		
		Output	5-way output (DC24V optocoupler isolation, open collector output) switching according to the control mode function		
	Pulse Signal	Input	2-way input (optocoupler isolation, RS-422 differential, open collector output)		
		Output	4-way output (A/B/Z phase RS-422 differential; Z phase open collector output)		
	Command	RS232	for PC communication (for "Servostudio" connection)		
		RS-485	for host remote control communication (1:n)		
		CAN	CANOPEN bus communication		
	Regenerative Functions		Connect regenerative resistor internally or externally pay attention to modifying internal parameters		
	Control Modes		6 control modes:speed control,position control,torque control,torque/speed control, speed/position control,torque/position,torque/speed/position mixed control		
Control Input		Alarm reset, proportional action switching, zero fixed function enabling, forward drive prohibited, reverse drive prohibited, external torque limit for forward rotation, external torque limit for reverse rotation, forward jog, reverse jog, forward reset switch, reverse reset switch, origin switch, emergency stop, servo enabling, gain switching			
Control Output		Servo ready, motor rotating, zero speed signal, speed arrival, position arrival, positioning approach signal, torque limit, speed limit, brake output, warning, servo failure, alarm code (3-digit output)			
Position Control	Pulse Input	Maximum command pulse frequency	The maximum low speed is 500Kpps, and the pulse width cannot be lower than 1μs; Open collector: maximum 200Kpps, pulse width not less than 2.5μs		
		Input pulse signal form	Differential input; open collector		
	Pulse output	Input pulse signal mode	pulse+direction, right angle phase difference (phase A+phase B), CW+CCW pulse		
		Command filter	Smooth filter, FIR filter		
Speed Control	Pulse Input	Output pulse form	Phase A and B: differential output Z-phase: differential output or open collector output		
		Frequency division ratio	Arbitrary frequency division		
	Pulse output	Output pulse function	Encoder position pulse and position pulse command (settable)		
		Control Input	Servo ON, alarm reset, reverse speed command, zero speed clamping, internal command selection input 1, internal command selection input 2, internal command selection input 3, internal command selection input 4, forward external torque limit input, reverse external torque limit input, emergency stop		
Torque Control	Control Output	Control Input	Servo ON, alarm reset, torque command reverse, zero speed clamp		
		Control Output	Alarm status, servo preparation, brake release, torque limit, speed limit output, emergency stop		
	Torque Command Input	(Factory default setting, range can be set by function code)			
	Speed Limit Function	Positive and negative internal speed limit P03.27, P03.28			
Similarities	Speed Observer Function	Yes			
	Vibration Control function	Yes			
	Adaptive Notch Filter	Yes			
	Auto adjustment function	Yes			
	Encoder output frequency division and multiplication	Yes			
	Internal location planning function	Yes			
Adjustment/Function Setting	Use the upper computer to set the software "Servostudio" to adjust				
Protective function	Over voltage, abnormal power supply, over current, overload, abnormal encoder, overspeed, excessive position deviation, abnormal parameters, etc.				

Location Mode Wiring

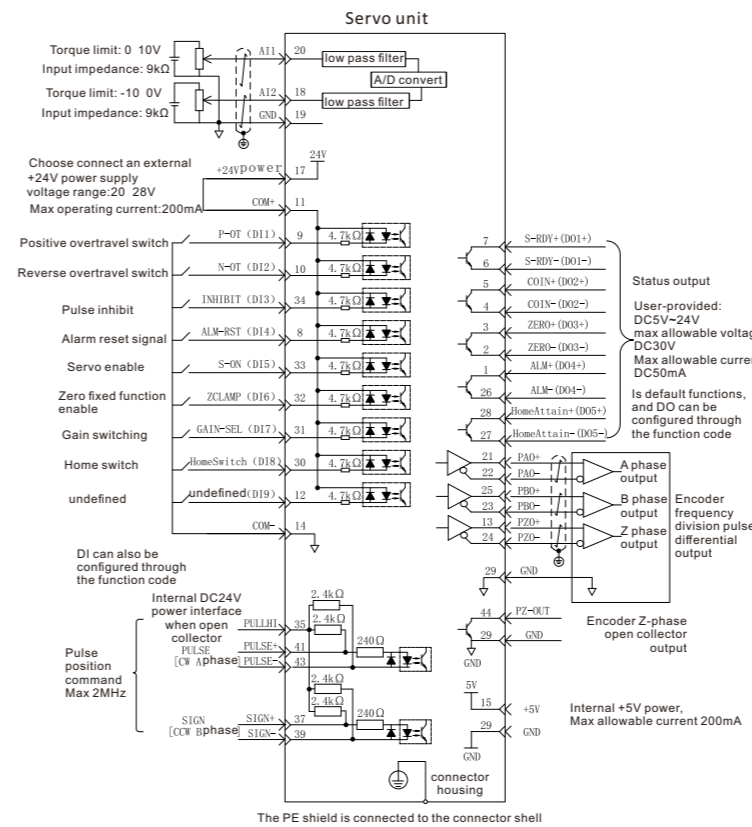

Speed/Torque Control Mode Block Diagram

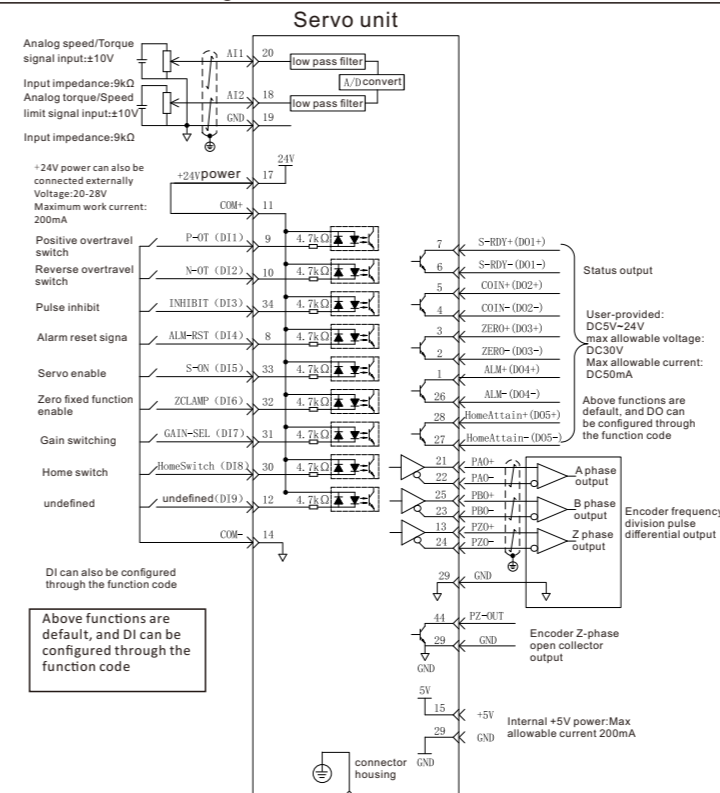

CN1 Terminal arrangement description

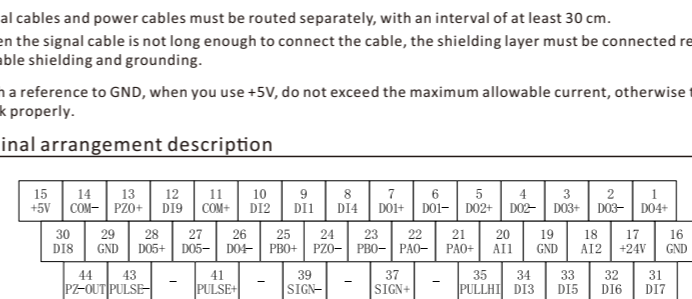

Model type show

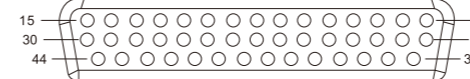

CN2 Illustration of the terminal arrangement of the absolute encoder

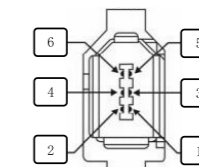

Terminal	Name	Function
1	+5V	PG power+5V
3	-	-
5	PS+	S+ phase
2	OV	Signal
4	-	-
6	PS-	S-phase

CN3, CN4 Illustration of terminal arrangement

Pin	Definition	Description	Terminal Pinout
1	CANH	CAN comm. port	8
2	CANL		
3	CGND	CAN comm. port	7
4	RS485+	RS485 comm. port	6
5	RS485-		
6	RS232-TXD	RS232 Sending end, connected with the receiving end of the host computer	5
7	RS232-RXD	RS232 The receiver is connected to the transmitter of the host computer	4
8	GND	Ground	3
Shell	PE	Ground shield	2

Servo System Wiring

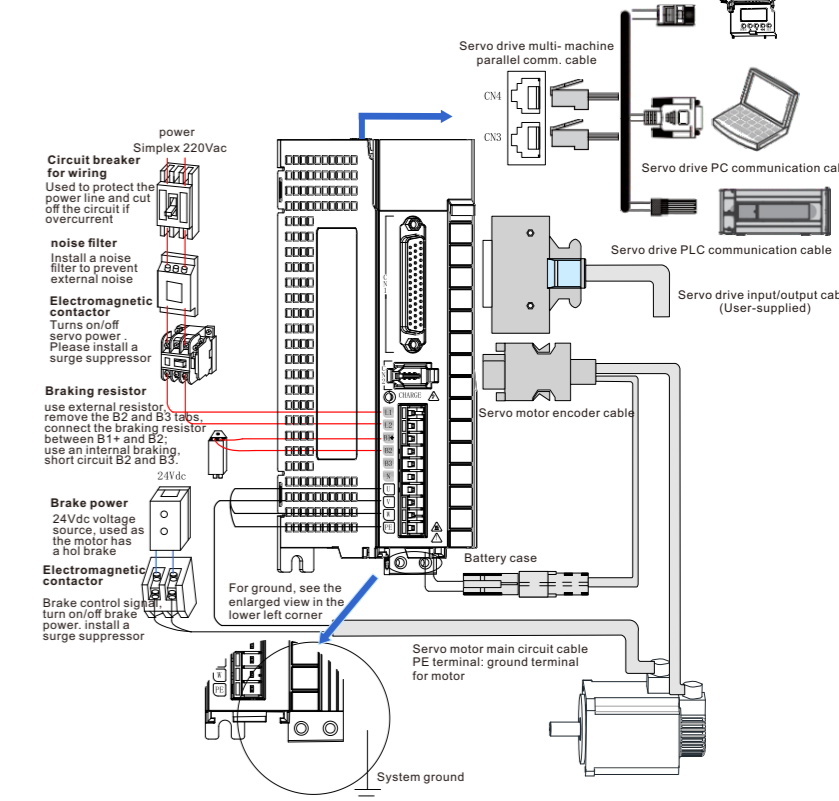

Please pay attention to the power supply capacity when connecting external control power supply or 24Vdc power supply, especially when supplying power to several drives or multiple brakes at the same time, insufficient power supply capacity will lead to insufficient supply current and failure of the drive or the brake. The braking power supply is a 24V DC voltage source. The power should refer to the motor model and meet the braking power requirements.

System wiring precautions:

- When connecting an external braking resistor, please remove the short-circuit wire between terminals B2 and B3 of the servo drive before connecting. Pay attention to modify the internal parameters.
- CN3 and CN4 define exactly the same communication interface for the two pins, which can be used arbitrarily between the two.
- In single-phase 220V wiring, the main circuit terminals are L1 and L2, and the reserved terminals should not be connected.

P02 Group Basic control parameters

Function code	Name	Unit	Factory setting	Effective way	Setting way	Related patterns
P02 00	Control Mode Selection	-	1	Effective immediately	Stop setting	-
P02 01	Absolute value system selection	-	0	Power up again	Stop setting	ALL
P02 02	rotating direction selection	-	0	Power up again	Stop setting	PST
P02 03	Output pulse phase	-	0	Power up again	Stop setting	PST
P02 05	stop model at S-ON off	-	0	Effective immediately	Stop setting	PST
P02 06	Fault No.2 Stop Mode Selection	-	0	Effective immediately	Stop setting	PST
P02 07	Choice of Overhaul Mode	-	1	Effective immediately	Stop setting	PST
P02 08	Fault No.1 Stop Mode Selection	-	0	Effective immediately	Stop setting	PST
P02 09	delay from brake output ON to command received	ms	250	Effective immediately	Run settings	PS
P02 10	delay from brake output OFF to motor de-energized in static state	ms	150	Effective immediately	Run settings	PS
P02 11	motor speed threshold at brake output OFF in rotating state	rpm	30	Effective immediately	Run settings	PS
P02 12	Rotate state, motor does not power to lock output Off delay	ms	500	Effective immediately	Run settings	PS
P02 15	LED Warning Display Select	-	0	Effective immediately	Run settings	PST
P02 18	Servo Enable (S-ON) Filter time constant	ms	0	Effective immediately	Run settings	PST
P02 21	Brake resistance minimum allowed by driver	Ω	-	-	Display	PST
P02 22	Built-in Brake Resistance Power	W	-	-	Display	PST
P02 23	Built-in brake resistance	Ω	-	-	Display	PST

