

SPEED - TORQUE CURVE

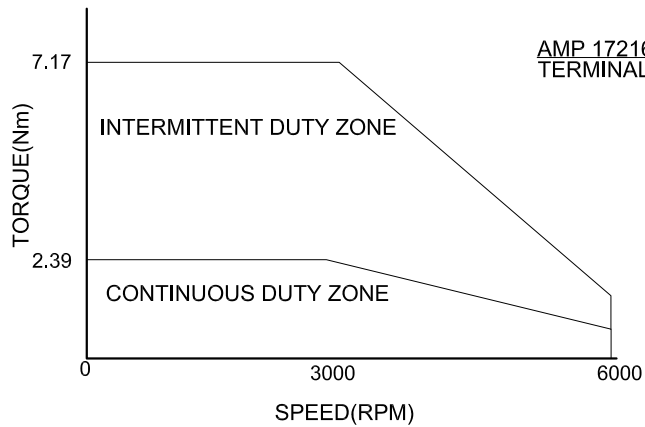

AMP 172169-1
TERMINAL AMP-170360-1

AMP 172167-1
TERMINAL AMP-170360-1

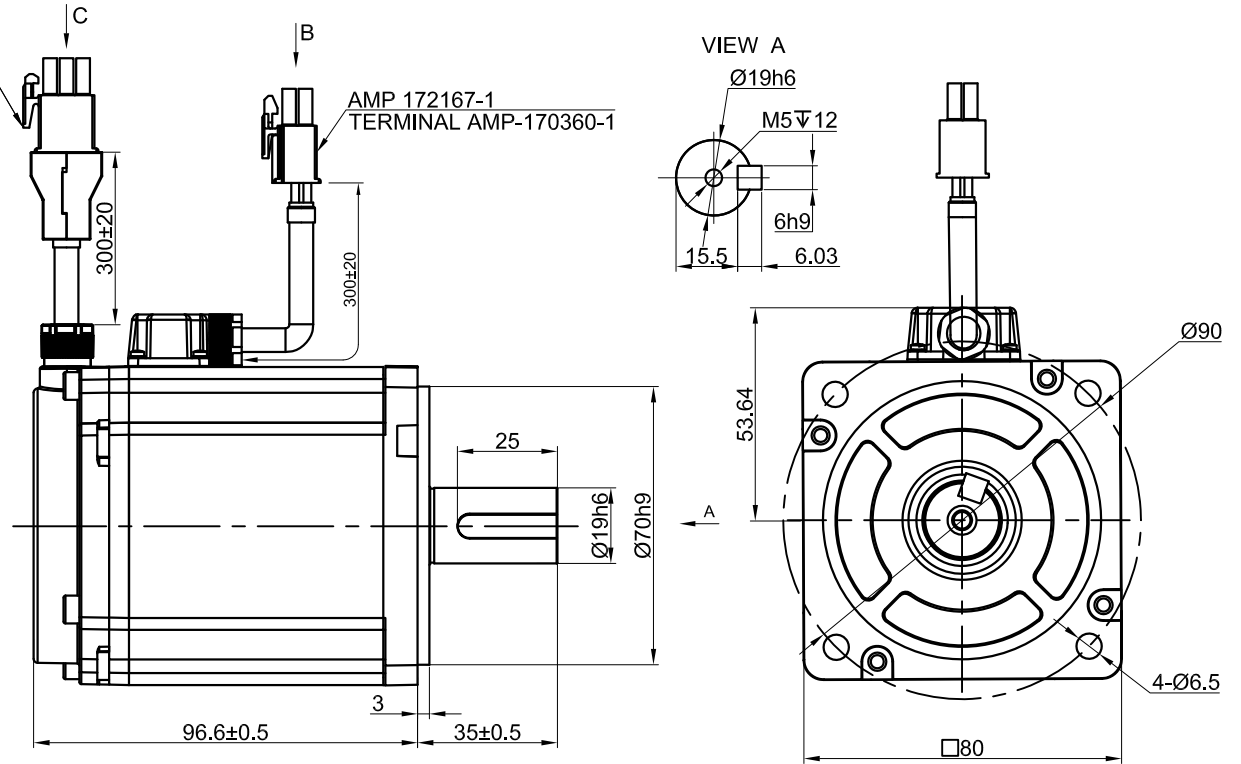

SPECIFICATION	VALUE
RATED VOLTAGE(VAC)	220
LINE COUNTER POTENTIAL(V/1000r/min)	38
RATED POWER(W)	750
RATED TORQUE(Nm)	2.39
PEAK TORQUE(Nm)	7.16
RATED SPEED(RPM)	3000
PEAK SPEED(RPM)	6000
RATED CURRENT(Amp)	3.8
PEAK CURRENT(Amp)	11.4
NUMBER OF STATOR SLOTS(S)	12
INSULATION CLASS	F
RESISTANCE(Ω)	1.72
INDUCTANCE(mH)	7.86/6.14
INERTIA($Kg \cdot m^2 \cdot 10^{-4}$)	1.56
POLES	5
ENCODER TYPE	17bit inc
IP RATING	IP65

WIRING DETAILS OF POWER CABLE CONNECTOR					
<p>VIEW B</p>	PIN No.	1	2	3	4
	DESCRIPTION	U	V	W	PE
	COLOR	RED	WHT	BLK	YEL/GRE

WIRING DETAILS OF ENCODER CABLE CONNECTOR										
<p>VIEW C</p>	PIN No.	1	2	3	4	5	6	7	8	9
	DESCRIPTION	FG	+5V	0V	—	—	—	SD+	—	SD-
	COLOR	SHIELD	RED	BLK	—	—	—	BLU	—	YEL

	APVD		1.11.2023
	CHKD		
2:1	DRN		
SCALE	SIGNATURE		DATE

AC SERVO MOTOR
E6M80-750H2A2-M17S