

DM556S

Digital Stepper Drive

Manual

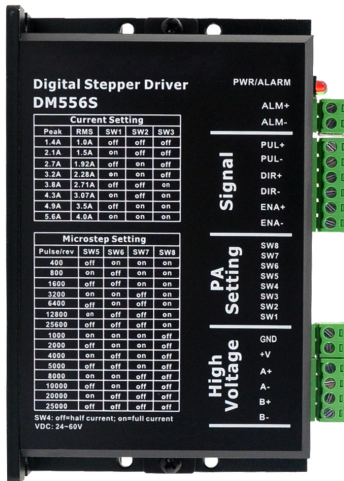

Contents

1. Overview.....	1
2. Features.....	1
3. Ports Introduction.....	2
3.1 Control Signal Input Ports.....	2
3.2 Power Interface Ports.....	3
3.3 Alarm Output Ports.....	3
4. Technological Index.....	4
5. Connections to Control Signal.....	4
5.1 Connections to Common Anode.....	5
5.2 Connections to Common Cathode.....	6
5.3 Connections to Differential Signal.....	7
5.4 Sequence Chart of Control Signals.....	8
6. DIP Switch Setting.....	9
6.1 Current Setting.....	9
6.2 Standstill current Setting.....	9
6.3 Microsteps Setting.....	9
7. Faults alarm and LED flicker frequency.....	10
8. Appearance and Installatlon Dimensions.....	11
9. Typical Connection.....	12
10. Frequently Asked Questions.....	13

1. Overview

The DM556S is a two phase digital stepper driver based on 32-bit DSP technology. The microstep resolution and output current can be set by users. It has advanced control algorithm which brings a unique level of system smoothness, provides optimum torque and mid-range instability. The control algorithm of Multi-Stepping can allow stepper motor a smooth system performance. The control algorithm of torque compensation can improve the torque of motor at high speed. The control algorithm of motor self-test and parameter auto-setup offers optimum responses with different motors and easy-to-use. The control algorithm of smoothness can enhance the acceleration and deceleration of motor. Its unique features make the DM556S an ideal solution to applications.

2. Features

- ◆ Parameter auto-setup and motor self-test
- ◆ Multi-Stepping inside, Small noise, low heat, smooth movement
- ◆ Torque compensation at high speed
- ◆ Variable current control technology, High current efficiency
- ◆ Accelerate and decelerate control inside, Great improvement in smoothness of starting or stopping the motor
- ◆ Storage the position of motor
- ◆ Optically isolated input and compatible with 5V ~ 24V
- ◆ User-defined microsteps
- ◆ Micro-step resolutions and Output current programmable
- ◆ Over current and over voltage protection

- ◆ Automatic detection, flexible selection of pulse edge count mode;
- ◆ Green light means running while red light means protection or off line

3. Ports Introduction

3.1 Control Signal Input Ports

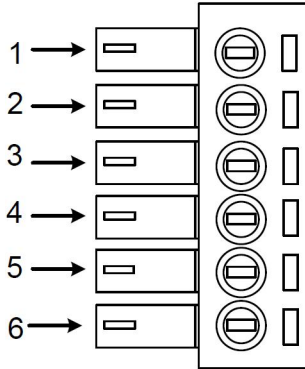

Port	Symbol	Name	Remark
1	PLS+	Pulse signal +	Compatible with 5V ~ 24V
2	PLS-	Pulse signal -	
3	DIR+	Direction signal+	
4	DIR-	Direction signal-	
5	ENA+	Enable signal +	
6	ENA-	Enable signal-	

3.2 Power Interface Ports

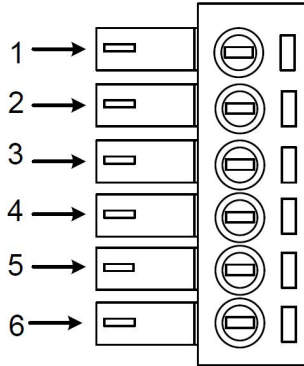

Port	Symbol	Name	Remark
1	GND	Input Power -	DC24V ~ 60V
2	+V	Input Power +	
3	A+	Phase A+	Motor Phase A
4	A-	Phase A-	
5	B+	Phase B+	Motor Phase B
6	B-	Phase B-	

3.3 Alarm Output Ports

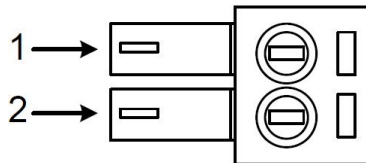

Port	Symbol	Name	Remark
1	ALM+	Alarm output +	Open collector output+
2	ALM-	Alarm output -	Open collector output-

4. Technological Index

Input Voltage		DC24V-60V
Continuous Current		7.5A
Max Pulse Frequency		200k
Default communication rate		57.6kbps
Protection		Overcurrent protection, peak $10A \pm 10\%$
		Over voltage protection peak 90VDC
Overall Dimensions(mm)		118×75.5×34
Weight		Approximate 260g
Environment	Environment	Avoid dust, oil fog and corrosive gases
	Operating Temperature	0 ~ 70℃
	Storage Temperature	-20℃~+80℃
	Humidity	40~90%RH
	Cooling method	Natural cooling or forced air cooling

5. Connections to Control Signal

5.1 Connections to Common Anode

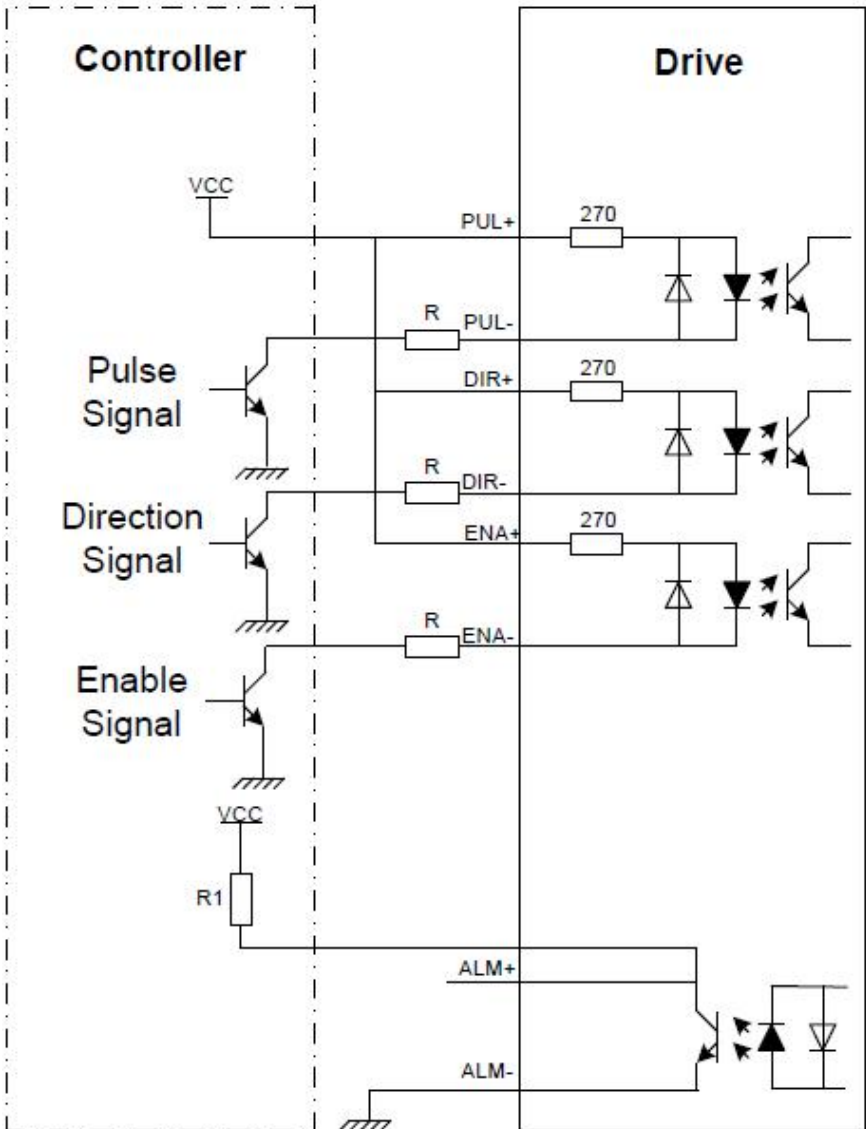

Remark:

VCC is compatible with 5V ~ 24V;

The R1 is connected to the control signal terminal and has a resistance of 3~5K.

5.2 Connections to Common Cathode

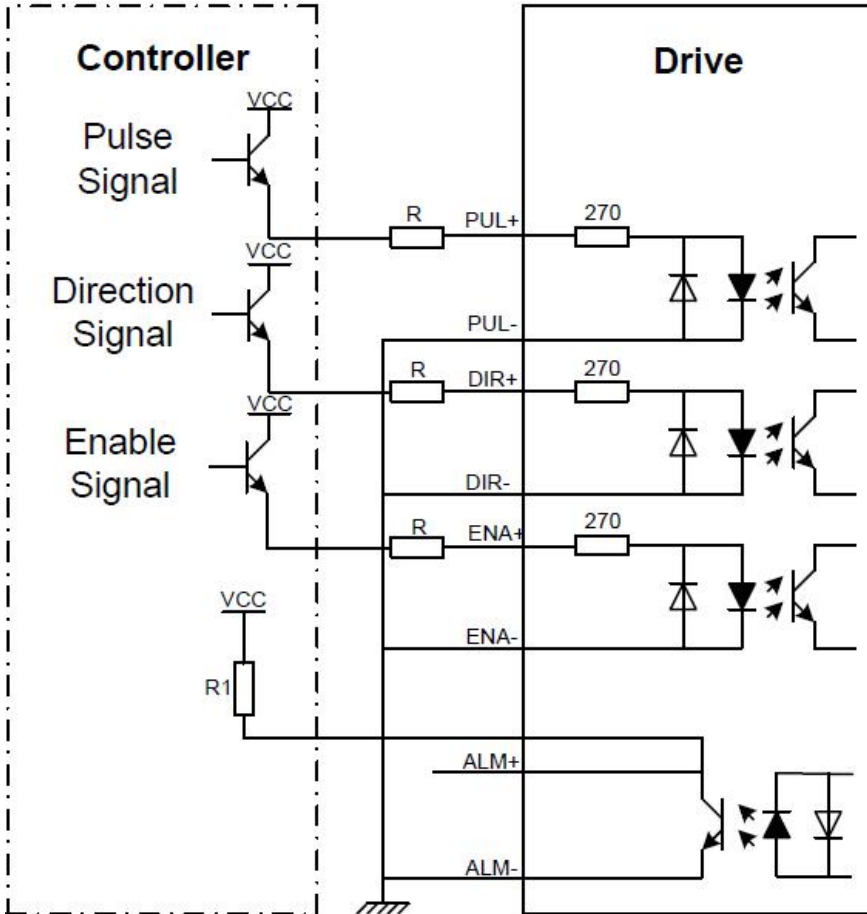

Remark:

VCC is compatible with 5V or 24V;

The R1 is connected to the control signal terminal and has a resistance of 3~5K.

5.3 Connections to Differential Signal

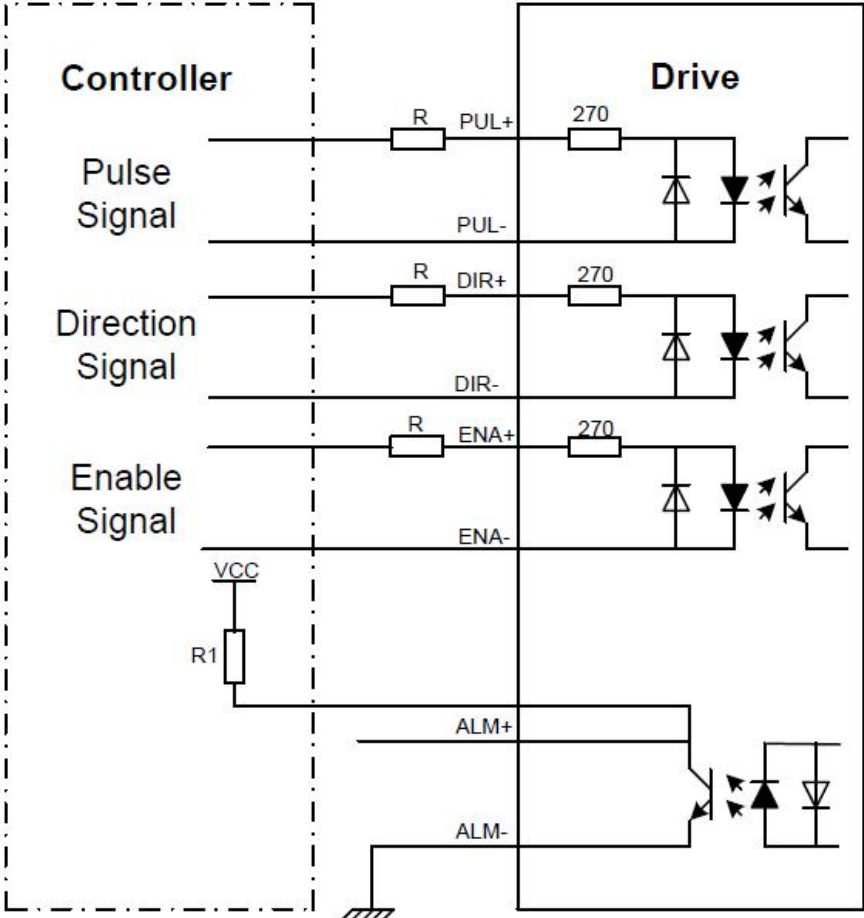

Remark:

VCC is compatible with 5V ~ 24V;

The R1 is connected to the control signal terminal and has a resistance of 3~5K.

5.4 Sequence Chart of Control Signals

In order to avoid some fault operations and deviations, PUL, DIR and ENA should abide by some rules, shown as following diagram:

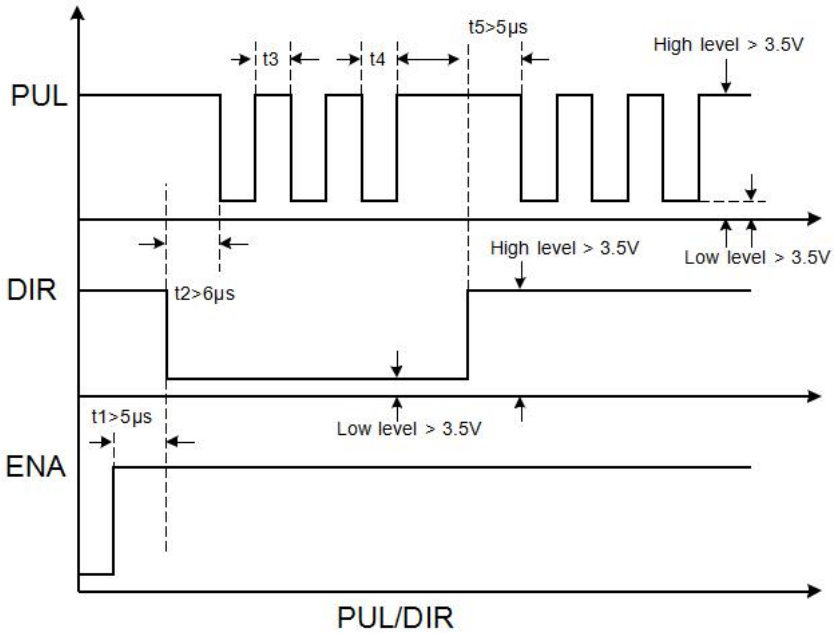

Remark:

- t_1 : ENA must be ahead of DIR by at least $5\mu\text{s}$. Usually, ENA+ and ENA- are NC (not connected).
- t_2 : DIR must be ahead of PUL active edge by $6\mu\text{s}$ to ensure correct direction;
- t_3 : Pulse width not less than $2.5\mu\text{s}$;
- t_4 : Low level width not less than $2.5\mu\text{s}$

6. DIP Switch Setting

6.1 Current Setting

The current setting is in the following table.

Dial switch Current		SW1	SW2	SW3
1.4A	1.0A	off	off	off
2.1A	1.5A	on	off	off
2.7A	1.92A	off	on	off
3.2A	2.28A	on	on	off
3.8A	2.71A	off	off	on
4.3A	3.07A	on	off	on
4.9A	3.5A	off	on	on
5.6A	4.0A	on	on	on

6.2 Standstill current Setting

SW4 is used for setting the standstill current , “off” means the standstill current is set to be half of the selected dynamic current or other current. While “on” means the standstill current is set to be the same as the selected dynamic current.

6.3 Microsteps Setting

The micro steps setting is in the following table.

Microsteps setting is in the following table.

Dial switch Microsteps	SW5	SW6	SW7	SW8
400	off	on	on	on
800	on	off	on	on
1600	off	off	on	on
3200	on	on	off	on
6400	off	on	off	on
12800	on	off	off	on
25600	off	off	off	on
1000	on	on	on	off
2000	off	on	on	off
4000	on	off	on	off
5000	off	off	on	off
8000	on	on	off	off
10000	off	on	off	off
20000	on	off	off	off
25000	off	off	off	off

7. Faults alarm and LED flicker frequency

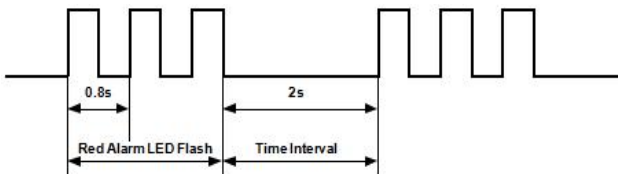

Flicker Frequenc	Description to the Faults
1	Error occurs when the motor coil current exceeds the drive's current limit.
2	Voltage reference error in the drive
3	Parameters upload error in the drive
4	Error occurs when the input voltage exceeds the drive's voltage limit.

8. Appearance and Installatlon Dimensions

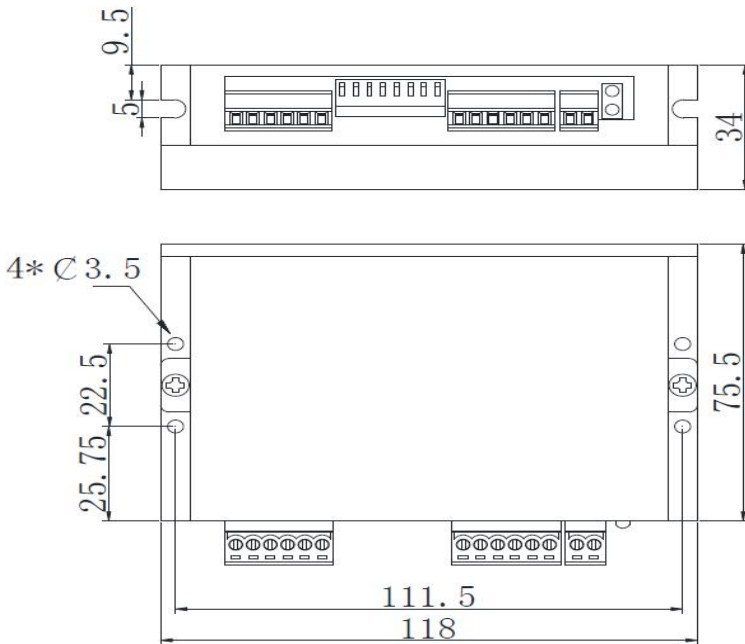

9. Typical Connection

Here is the typical connection of DM556S.

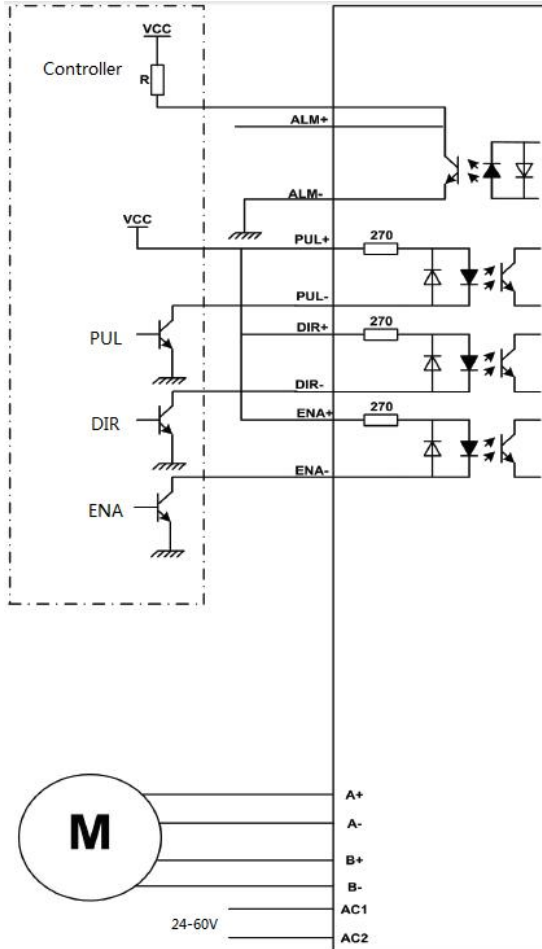

10. Frequently Asked Questions

10.1 The power light is off

- No power input, please check the power supply circuit.
- The voltage is too low.

10.2 The drive alarms when power on

- Please check the motor is connected with the drive.
- The stepper digital drive is over voltage or under voltage. Please lower or increase the input voltage.

10.3 The motor does not rotate after being given pulse signals

- Please check the input pulse signal wires are connected in reliable way.
- Please make sure the input pulse mode is corresponding with the real input mode.
- The Driver is disabled