

User's Manual

For

CL86T

Closed Loop Stepper Driver



CL86T

Closed-loop Stepper Driver

24~80VDC, 8.2A Peak, Closed-loop, No Tuning

1. Introductions

This Closed-loop Stepper Driver offers an alternative for applications requiring high performance and high reliability when the servo was the only choice, while it remains cost-effective. The system includes a 2-phase stepper motor combined with a fully digital, high performance drive and an internal encoder which is used to close the position, velocity and current loops in real time, just like servo systems. It combines the best of servo and stepper motor technologies, and delivers unique capabilities and enhancements over both, while at a fraction of the cost of a servo system.

1.1 Features

- Closed-loop, eliminates loss of synchronization
- Broader operating range – higher torque and higher speed
- Reduced motor heating and more efficient
- Smooth motion and super-low motor noise
- Do not need a high torque margin
- No Tuning and always stable
- Quick response, no delay and almost no settle time
- High torque at starting and low speed, high stiffness at standstill
- Offer servo-like performance at a much lower cost

1.2 Applications

Its great feature of quick response and no hunting make this Closed-loop Stepper Driver ideal for applications such as bonding and vision systems in which rapid motions with a short distance are required and hunting would be a problem. And it is ideal for applications where the equipment uses a belt-drive mechanism or otherwise has low rigidity and you don't want it to vibrate when stopping.

2. Specifications

2.1 Electrical Specifications

Parameter	Min	Typical	Max	Unit
Input Voltage	24	48	80	VDC
Output Current	0	-	8.2	A
Pulse Input Frequency	0	-	200	kHz
Logic Signal Current	7	10	16	mA
Isolation Resistance	500	-	-	MΩ

2.2 Operating Environment

Cooling	Natural Cooling or Forced cooling	
Operating Environment	Environment	Avoid dust, oil fog and corrosive gases
	Storage Temperature	-20°C — 65°C (-4°F — 149°F)
	Ambient Temperature	0°C — 50°C (32°F — 122°F)
	Humidity	40%RH — 90%RH
	Operating Temperature (Heat Sink)	70°C (158°F) Max
Storage Temperature	-20°C — 65°C (-4°F — 149°F)	
Weight	580 g (20.5 oz)	

2.3 Mechanical Specifications

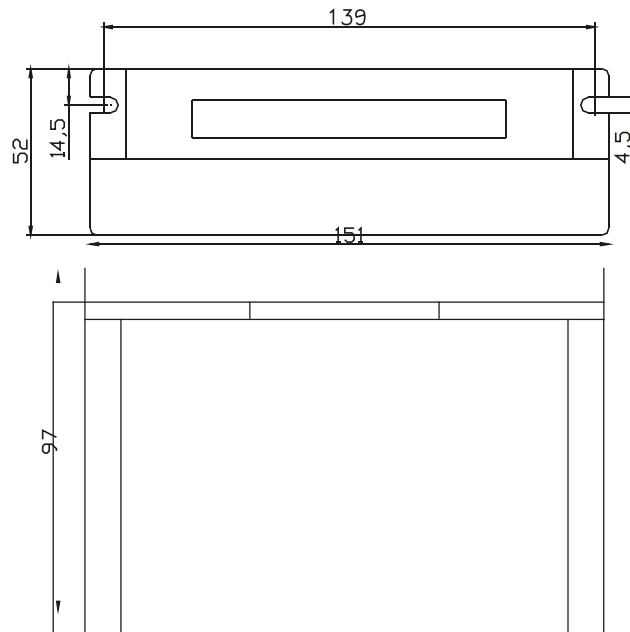

2.4 Protection Indications

The green indicator turns on when power-up. When drive protection is activated, the red LED blinks periodically to indicate the error type.

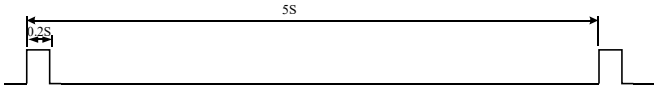
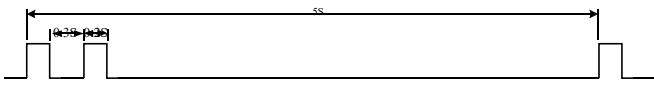
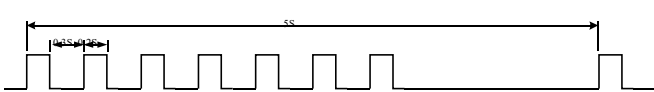
Priority	Time(s) of Blink	Sequence wave of RED LED	Description
1st	1		Over-current protection
2nd	2		Over-voltage protection
3rd	7		Position Following Error

3. Connectors and Pin Assignment

The CL86T has four connectors, connector for control signals connections, connector for status signal connections, connector for encoder feedback and connector for power and motor connections.

Control Signal Connector – Screw Terminal			
Pin	Name	I/O	Description
1	PUL+	I	<u>Pulse Signal</u> : In single pulse (pulse/direction) mode, this input represents pulse signal, each rising or falling edge active (software configurable, see Closed-loop Stepper Driver software manual for more detail); In double pulse mode (software configurable), this input represents clockwise (CW) pulse, active both at high level and low level. 4.5-24V when PUL-HIGH, 0-0.5V when PUL-LOW. For reliable response, pulse width should be longer than 2.5 μ s.
2	PUL-	I	
3	DIR+	I	<u>Direction Signal</u> : In single-pulse mode, this signal has low/high voltage levels, representing two directions of motor rotation. In double-pulse mode (software configurable), this signal is counter-clock (CCW) pulse, active both at high level and low level. For reliable motion response, DIR signal should be ahead of PUL signal by 5 μ s at least. 4.5-24V when DIR-HIGH, 0-0.5V when DIR-LOW. Please note that rotation direction is also related to motor-driver-encoder wiring match. Exchanging both the connection of two wires for a coil and an encoder channel to the driver the connection will reverse motion direction. Or you can toggle the SW5 to reverse the motion direction.
4	DIR-	I	
5	ENA+	I	<u>Enable Signal</u> : This signal is used for enabling/disabling the driver. In default, high level (NPN control signal) for enabling the driver and low level for disabling the driver. Usually left UNCONNECTED (ENABLED) . Please note that PNP and Differential control signals are on the contrary, namely Low level for enabling. The active level of ENA signal is software configurable.
6	ENA-	I	

Connectors and Pin Assignment (Continued)

Status Signal Connector – Screw Terminal			
Pin	Name	I/O	Description
1	Pend+	O	<u>In-position Signal</u> : OC output signal, active when the difference between the actual position and the command position is zero. This port can sink or source 20mA current at 24V. The resistance between Pend+ and Pend- is active at high impedance.
2	Pend-	O	
3	ALM+	O	<u>Alarm Signal</u> : OC output signal, active when one of the following protection is activated: over-voltage, over current and position following error. This port can sink or source 20mA current at 24V. In default, the resistance between ALM+ and ALM- is low impedance in normal operation and become high when CL86T goes into error. The active level of alarm signal is software configurable. See Hybrid servo software operational manual for more detail.
4	ALM-	O	

Encoder Feedback Connector – Screw Terminal			
Pin	Name	I/O	Description
1	EB+	I	Encoder channel B+ input
2	EB-	I	Encoder channel B- input
3	EA+	I	Encoder channel A+ input
4	EA-	I	Encoder channel A- input
5	VCC	O	+5V @ 100 mA max.
6	EGND	GND	Signal ground

Power and Motor Connector – Screw Terminal			
Pin	Name	I/O	Description
1	A+	O	Motor Phase A+
2	A-	O	Motor Phase A-
3	B+	O	Motor Phase B+
4	B-	O	Motor Phase B-
5	+Vdc	I	Power Supply Input (Positive) 30-72VDC recommended, leaving rooms for voltage fluctuation and back-EMF.
6	GND	GND	Power Ground (Negative)

RS232 Communication Port

It is used to configure the close-loop current, open-loop current, position following error limit and etc. See Closed-loop Stepper Driver software operational manual for more information.

RS232 Communication Port			
Pin	Name	I/O	Description
1	NC	-	Not connected.
2	+5V	O	+5V power only for STU (Simple Tuning Unit).
3	TxD	O	RS232 transmit.
4	GND	GND	Ground.
5	RxD	I	RS232 receive.
6	NC	-	Not connected.

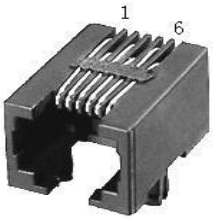

4. DIP Switch Settings

4.1 Microstep Resolution (SW1-SW4)

Steps/Revolution	SW1	SW2	SW3	SW4
Software Configured (Default 1600)	on	on	on	on
800	off	on	on	on
1600	on	off	on	on
3200	off	off	on	on
6400	on	on	off	on
12800	off	on	off	on
25600	on	off	off	on
51200	off	off	off	on
1000	on	on	on	off
2000	off	on	on	off
4000	on	off	on	off
5000	off	off	on	off
8000	on	on	off	off
10000	off	on	off	off
20000	on	off	off	off
40000	off	off	off	off

4.2 Motor Direction (SW5)

	ON	OFF
SW5	Motor direction is positive.	Motor direction is negative.

Note: The actual motor direction is also related to DIR level.

4.3 Motor Selection (SW6)

It is reserved for future use. Now it has no function for SW6.

4.4 Current Control

The motor current will be adjusted automatically regarding to the load or the stator-rotor relationship. However, the user can also configure the current in the tuning software. The configurable parameters include close-loop current, holding current, encoder resolution, micro step and etc.

5. Typical Connections

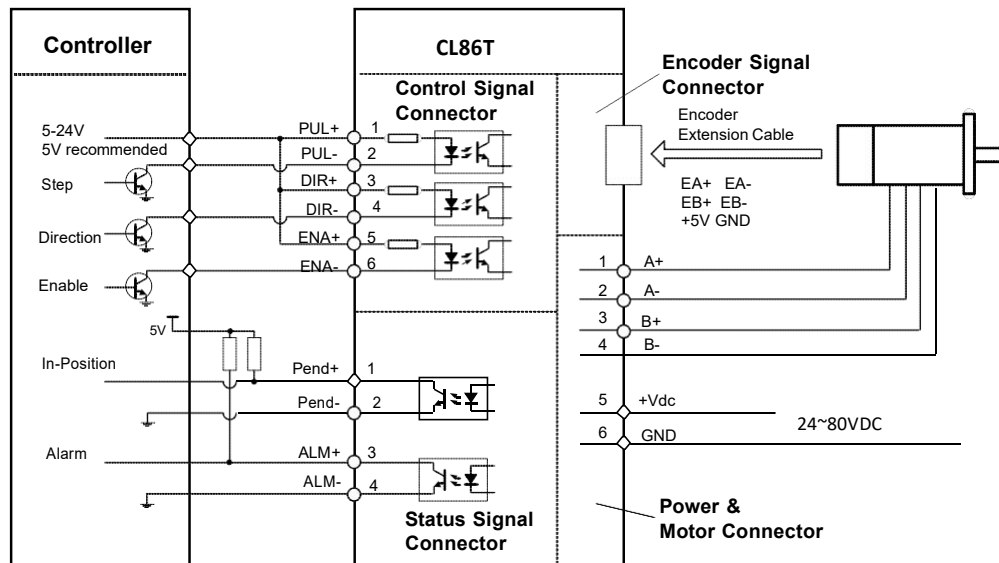

Connections to controller of sinking output

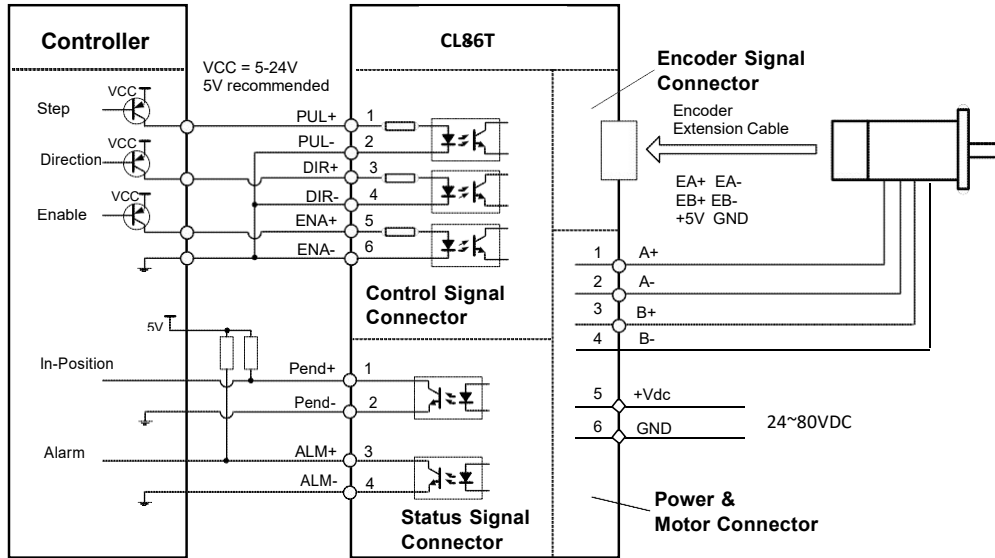

Connections to controller of sourcing output

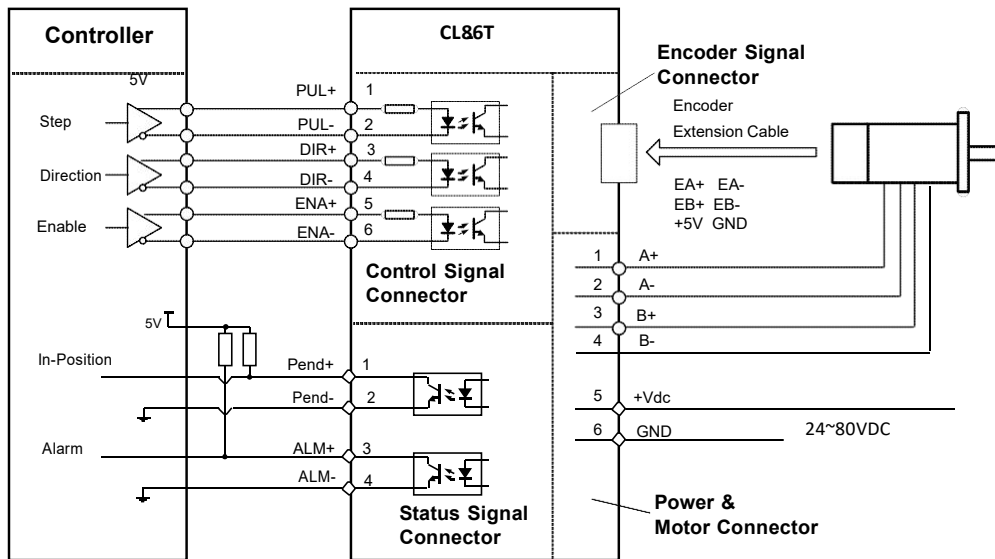

Connections to controller of differential output