

SPECIFICATION	VALUE
NO. of PHASES	3
NO. of POLES	4
RATED VOLTAGE(V)	24
RATED CURRENT(A)	5±10%
RATED POWER(W)	84
RATED SPEED w/o GEARBOX(RPM)	3500±10%
RATED TORQUE w/o GEARBOX(mN.m)	230
GEAR RATIO	10
EFFICIENCY	85.00%REF
MAX.PERMISSIBLE TORQUE(Nm)[lb-in]	6[53.10]
BACKLASH@NO-LOAD(°)	0.8
SENSOR	HALL SENSOR
INSULATION CLASS	CLASS B
INSULATION RESISTANCE	100MΩ MIN @ 500VDC
DIELECTRIC STRENGTH TEST	500VDC for 1 MINUTE
BEARING TYPE	NMB BALL BEARING, C3

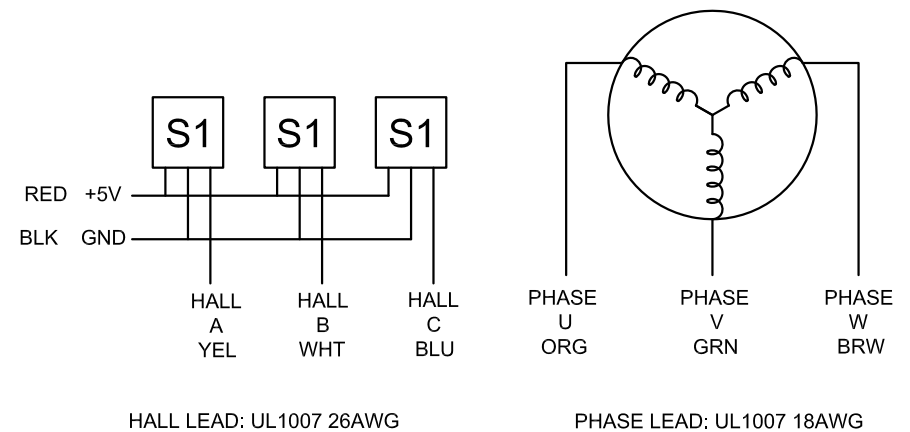

SCALE	APVD		8.22.2020
	CHKD		
	1.5:1	DRN	
	SIGNATURE	DATE	

BRUSHLESS DC MOTOR

57BLR50-24-01-HG10